

RIGOL

Performance Verification Guide

RSA5000 Series Real-Time Spectrum Analyzer

Oct. 2025

RIGOL TECHNOLOGIES CO., LTD

Guaranty and Declaration

Copyright

© 2025 RIGOL TECHNOLOGIES CO., LTD. All Rights Reserved.

Trademark Information

RIGOL is a registered trademark of RIGOL TECHNOLOGIES CO., LTD.

Publication Number

PVD20104-1110

Notices

- RIGOL products are covered by P.R.C. and foreign patents, issued and pending.
- RIGOL reserves the right to modify or change parts of or all the specifications and pricing policies at the company's sole decision.
- Information in this publication replaces all previously released materials.
- Information in this publication is subject to change without notice.
- RIGOL shall not be liable for either incidental or consequential losses in connection with the furnishing, use, or performance of this manual, as well as any information contained.
- Any part of this document is forbidden to be copied, photocopied, or rearranged without prior written approval of RIGOL.

Product Certification

RIGOL guarantees that this product conforms to the national and industrial standards in China as well as the ISO9001:2015 standard and the ISO14001:2015 standard. Other international standard conformance certifications are in progress.

Contact Us

If you have any problem or requirement when using our products or this manual, please contact RIGOL.

E-mail: service@rigol.com

Website: www.rigol.com

General Safety Summary

Please review the following safety precautions carefully before putting the instrument into operation so as to avoid any personal injury or damage to the instrument and any product connected to it. To prevent potential hazards, please follow the instructions specified in this manual to use the instrument properly.

Use Proper Power Cord.

Only the exclusive power cord designed for the instrument and authorized for use within the local country could be used.

Ground the Instrument.

The instrument is grounded through the Protective Earth lead of the power cord. To avoid electric shock, connect the earth terminal of the power cord to the Protective Earth terminal before connecting any input or output terminals.

Connect the Probe Correctly.

If a probe is used, the probe ground lead must be connected to earth ground. Do not connect the ground lead to high voltage. Improper way of connection could result in dangerous voltages being present on the connectors, controls or other surfaces of the oscilloscope and probes, which will cause potential hazards for operators.

Observe All Terminal Ratings.

To avoid fire or shock hazard, observe all ratings and markers on the instrument and check your manual for more information about ratings before connecting the instrument.

Use Proper Overvoltage Protection.

Ensure that no overvoltage (such as that caused by a bolt of lightning) can reach the product. Otherwise, the operator might be exposed to the danger of an electric shock.

Do Not Operate Without Covers.

Do not operate the instrument with covers or panels removed.

Do Not Insert Objects into the Air Outlet.

Do not insert objects into the air outlet, as doing so may cause damage to the instrument.

Use Proper Fuse.

Please use the specified fuses.

Avoid Circuit or Wire Exposure.

Do not touch exposed junctions and components when the unit is powered on.

Do Not Operate with Suspected Failures.

If you suspect that any damage may occur to the instrument, have it inspected by **RIGOL** authorized personnel before further operations. Any maintenance, adjustment or replacement especially to circuits or accessories must be performed by **RIGOL** authorized personnel.

Provide Adequate Ventilation.

Inadequate ventilation may cause an increase of temperature in the instrument, which would cause damage to the instrument. So please keep the instrument well ventilated and inspect the air outlet and the fan regularly.

Do Not Operate in Wet Conditions.

To avoid short circuit inside the instrument or electric shock, never operate the instrument in a humid environment.

Do Not Operate in an Explosive Atmosphere.

To avoid personal injuries or damage to the instrument, never operate the instrument in an explosive atmosphere.

Keep Product Surfaces Clean and Dry.

To avoid dust or moisture from affecting the performance of the instrument, keep the surfaces of the instrument clean and dry.

Prevent Electrostatic Impact.

Operate the instrument in an electrostatic discharge protective environment to avoid damage induced by static discharges. Always ground both the internal and external conductors of cables to release static before making connections.

Use the Battery Properly.

Do not expose the battery (if available) to high temperature or fire. Keep it out of the reach of children. Improper change of a battery (lithium battery) may cause an explosion. Use the **RIGOL** specified battery only.

Handle with Caution.

Please handle with care during transportation to avoid damage to keys, knobs, interfaces, and other parts on the panels.

Safety Notices and Symbols

Safety Notices in this Manual:



WARNING

Indicates a potentially hazardous situation or practice which, if not avoided, will result in serious injury or death.



CAUTION

Indicates a potentially hazardous situation or practice which, if not avoided, could result in damage to the product or loss of important data.

Safety Terms on the Product:

DANGER It calls attention to an operation, if not correctly performed, could result in injury or hazard immediately.

WARNING It calls attention to an operation, if not correctly performed, could result in potential injury or hazard.

CAUTION It calls attention to an operation, if not correctly performed, could result in damage to the product or other devices connected to the product.

Safety Symbols on the Product:



Hazardous Voltage



Safety Warning



Protective Earth
Terminal



Chassis Ground



Test Ground

Document Overview

This manual is designed to guide you to properly test the performance specifications of **RIGOL** RSA5000 series real-time spectrum analyzer in GPSA mode. For the operation methods mentioned in the test procedures, refer to User Guide of this product.

Main Contents in this Manual:

Chapter 1 Overview

This chapter introduces the preparations before performing the performance verification tests and the notices.

Chapter 2 Performance Verification Test

This chapter introduces the limit, test devices required as well as the test method and procedures of each performance specification.

Appendix Test Record Form

The appendix provides a test record form for users to record the test results and judge whether each performance specification can meet the requirement.

Format Conventions in this Manual:

Front panel key: The key on the front panel is denoted by the format of "Key Name (Bold) + Text Box" in the manual. For example, **FREQ** indicates the "FREQ" key on the front panel.

Menu softkey: The menu softkey is denoted by the format of "Menu Word (Bold) + Character Shading". For example, **Center Freq** denotes the "Center Freq" menu softkey under **FREQ**.

Operation step: The next step of operation is denoted by an arrow "→". For example, **FREQ** → **Center Freq** denotes that first press **FREQ**, and then press the **Center Freq** softkey.

Content Conventions in this Manual:

The RSA5000 series spectrum analyzer includes the following models. This manual takes RSA5065-TG as an example to illustrate the test methods for the performance verification of the RSA5000 series.

Model	Frequency Range	TG
RSA5065	9 kHz to 6.5 GHz	None
RSA5032	9 kHz to 3.2 GHz	None
RSA5065-TG	9 kHz to 6.5 GHz	6.5 GHz
RSA5032-TG	9 kHz to 3.2 GHz	3.2 GHz
RSA5065N	9 kHz to 6.5 GHz	6.5 GHz
RSA5032N	9 kHz to 3.2 GHz	3.2 GHz

NOTE: The RSA5000N models include hardware capability not in the RSA5000-TG. The RSA5000-TG models cannot be used in VNA mode.

Contents

Guaranty and Declaration	I
General Safety Summary	II
Safety Notices and Symbols	IV
Document Overview	V
Chapter 1 Overview	1-1
Test Preparations	1-1
Test Result Record.....	1-2
Specifications.....	1-2
Chapter 2 Performance Verification Test	2-1
Displayed Average Noise Level (DANL) Test.....	2-2
Specification.....	2-2
Test Device	2-2
Test Connection Diagram.....	2-2
Test Procedures.....	2-2
Test Record Form.....	2-4
SSB Phase Noise Test	2-5
Specification.....	2-5
Test Devices.....	2-5
Test Connection Diagram.....	2-5
Test Procedures.....	2-5
Test Record Form.....	2-6
Absolute Amplitude Accuracy Test.....	2-7
Specification.....	2-7
Test Devices.....	2-7
Test Connection Diagram.....	2-7
Test Procedures.....	2-8
Test Record Form.....	2-9
Frequency Response Test.....	2-10
Specification.....	2-10
Test Devices.....	2-10
Test Connection Diagram.....	2-10
Test Procedures.....	2-11
Test Record Form.....	2-12
Second Harmonic Distortion Test	2-14
Specification.....	2-14
Test Devices.....	2-14
Test Connection Diagram.....	2-14
Test Procedures.....	2-14

Test Record Form.....	2-15
TOI Distortion Test	2-16
Specification	2-16
Test Devices	2-16
Test Connection Diagram.....	2-17
Test Procedures	2-17
Test Record Form.....	2-19
1 dB Gain Compression Test.....	2-20
Specification	2-20
Test Devices	2-20
Test Connection Diagram.....	2-21
Test Procedures	2-21
Test Record Form.....	2-22
Input Attenuation Switching Uncertainty Test	2-23
Specification	2-23
Test Devices	2-23
Test Connection Diagram.....	2-24
Test Procedures	2-24
Test Record Form.....	2-26
10 MHz Reference Output Accuracy Test	2-27
Specification	2-27
Test Devices	2-27
Test Connection Diagram.....	2-27
Test Procedures	2-27
Test Record Form.....	2-27
Appendix Test Record Form	1

Chapter 1 Overview

Test Preparations

Before performing the test, make the following preparations.

- 1) Warm up the RSA5000 spectrum analyzer for at least 40 minutes.
- 2) Make sure that the instrument is within the calibration period (18 months) and perform self-calibration on the spectrum analyzer. Press **System** → **Alignment** → **Align Now**, and the spectrum analyzer performs self-calibration immediately using internal calibration source.
- 3) The test devices required should fulfill the requirements of the "Specification" column as shown in Table 1-1. You can also use the recommended models in the following table to make measurement.

Table 1-1 Test Devices Required

Device	Specification	Qty.	Recommended Model
Signal Generator	Amplitude accuracy: ± 0.6 dB Single-sideband phase noise: < -126 dBc/Hz	2	Agilent N5181A
Frequency Counter	Frequency range: 10 MHz \pm 100 Hz Support single trigger and external reference input Gate time: ≥ 10 s Frequency resolution: 10 digits/s	1	Agilent 53181A
Power Meter and Power Sensor	Resolution: 0.001 dB Reference accuracy: $\pm 1.2\%$ Frequency range: 9 kHz to 18 GHz Max SWR: 1.13 (9 kHz to 2 GHz) 1.19 (2 GHz to 14 GHz) 1.22 (14 GHz to 16 GHz) 1.26 (16 GHz to 18 GHz) Amplitude range: 1 nW to 100 mW (-60 dBm to +20 dBm)	1	Agilent N1913A and Agilent E9304A
Power Divider	Frequency range: 9 kHz to 13.2 GHz Insertion loss: 6 dB, nominal Output track: < 0.25 dB Equivalent output SWR: $< 1.22:1$	1	Agilent 11667A
Low-pass Filter ^[1]	Cut-off frequency: 50 MHz	1	--
Low-pass Filter ^[1]	Cut-off frequency: 300 MHz	1	--
Low-pass Filter ^[1]	Cut-off frequency: 1 GHz	1	--
Attenuator/Switch Driver	Compatible with Agilent 8494H and 8496H programmable step attenuator	1	Agilent 11713B

Step Attenuator	Step: 1 dB Attenuation range: 0 dB to 11 dB Frequency range: 50 MHz \pm 1 MHz Connector: N (F) Attenuation repeatability: \pm 0.03 dB	1	Agilent 8494H
Step Attenuator	Step: 10 dB Attenuation range: 0 dB to 110 dB Frequency range: 50 MHz \pm 1 MHz Connector: N (F) Attenuation repeatability: \pm 0.03 dB	1	Agilent 8496H
Attenuator Interconnect Kit	Connect Agilent 8494H and Agilent 8496H	1	Agilent 11716A
50 Ω Matched Load	Impedance: 50 Ω , nominal Connector: N (M)	1	--
Dual-N Cable	N (M)-N (M) cable	3	--
Dual-BNC Cable	BNC (M)-BNC (M) cable	1	--
N-SMA Cable	N (M)-SMA (M) cable	2	--

Note^[1]: The connecting terminals of the low-pass filter used in this manual are two SMA female terminals. In the actual test, the type of the connecting terminals of the low-pass filter may differ; please select proper connecting cable and adaptor according to the actual type of the connecting terminals.

Test Result Record

Record and keep the test result of each test. In the Appendix of this manual, a test result record form which lists all the test items and their corresponding performance limits as well as spaces for users to record the test results, is provided.

Tip:

It is recommended that users photocopy the test record form before each test and record the test results in the copy so that the form can be used repeatedly.

Specifications

The specification of each test item is provided in Chapter 2. For other technical parameters, refer to *RSA5000 DataSheet* (available to download them from **RIGOL** website: www.rigol.com)

Tip:

All the specifications are only valid when the spectrum analyzer has been warmed up for more than 40 minutes.

Chapter 2 Performance Verification Test

This chapter introduces the performance verification test methods and test process of RSA5000 series real-time spectrum analyzer in GPSA mode.

Note:

- 1) Before executing the performance verification test, ensure that the spectrum analyzer has undergone the self-calibration.
- 2) Before performing each test, ensure that the spectrum analyzer has been warmed up for at least 40 minutes.
- 3) Press **Preset** to reset the instrument to the factory setting before or after executing any of the following tests.
- 4) For amplitude-related tests, perform self-calibration on the instrument (press **System** → **Alignment** → **Align Now**) before the test.
- 5) Definitions of "Typical", "Nominal", and "Measured" values for this product are as follows.
 - Typical: typical performance, which 80% of the measurement results will meet at room temperature (approximately 25°C). The data are not warranted and do not include the measurement uncertainty.
 - Nominal: the expected mean or average performance or a designed attribute (such as the 50Ω connector). This data is not warranted and is measured at room temperature (approximately 25°C).
 - Measured (meas.): an attribute measured during the design phase which can be compared to the expected performance, i.g. the amplitude drift varies with time. This data is not warranted and is measured at room temperature (approximately 25°C).

Displayed Average Noise Level (DANL) Test

Specification

DANL			
		RSA5032/RSA5032-TG/RSA5032N	RSA5065/RSA5065-TG/RSA506N
		attenuation = 0 dB, sample detector, trace averages ≥ 50, tracking generator off, normalized to 1 Hz, 20°C to 30°C, input impedance = 50 Ω.	
PA off	9 kHz to 100 kHz	<-120 dBm (typical)	<-120 dBm (typical)
	100 kHz to 20 MHz	<-135 dBm, <-140 dBm (typical)	<-135 dBm, <-140 dBm (typical)
	20 MHz to 1.5 GHz	<-142 dBm, <-145 dBm (typical)	<-142 dBm, <-145 dBm (typical)
	1.5 GHz to 2.7 GHz	<-140 dBm, <-143 dBm (typical)	<-140 dBm, <-143 dBm (typical)
	2.7 GHz to 3.2 GHz	<-138 dBm, <-141 dBm (typical)	<-138 dBm, <-141 dBm (typical)
	3.2 GHz to 5.5 GHz		<-138 dBm, <-143 dBm (typical)
	5.5 GHz to 6.5 GHz		<-136 dBm, <-141 dBm (typical)
PA on	100 kHz to 20 MHz	<-152 dBm, <-160 dBm (typical)	<-152 dBm, <-160 dBm (typical)
	20 MHz to 1.5 GHz	<-162 dBm, <-165 dBm (typical)	<-162 dBm, <-165 dBm (typical)
	1.5 GHz to 2.7 GHz	<-160 dBm, <-163 dBm (typical)	<-160 dBm, <-163 dBm (typical)
	2.7 GHz to 3.2 GHz	<-158 dBm, <-161 dBm (typical)	<-158 dBm, <-161 dBm (typical)
	3.2 GHz to 5.5 GHz		<-156 dBm, <-161 dBm (typical)
	5.5 GHz to 6.5 GHz		<-154 dBm, <-159 dBm (typical)

Test Device

1. 50 Ω Matched Load × 1

Test Connection Diagram

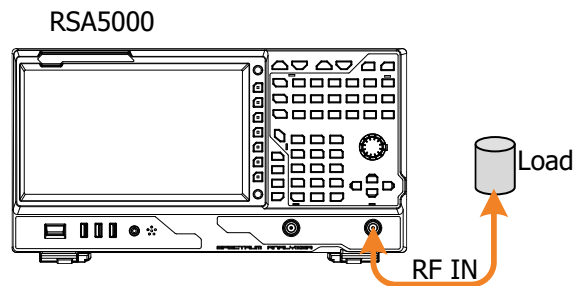

Figure 2-1 DANL Test Connection Diagram

Test Procedures

1. Connect the 50 Ω matched load to the RF input terminal of RSA5000, as shown in Figure 2-1.
2. Configure the spectrum analyzer:
 - a) Set the preamplifier to Off.

- b) Set the span to 1 kHz.
 - c) Set the detector type to Sample.
 - d) Set the input attenuation to 0 dB.
 - e) Set the resolution bandwidth to 1 kHz, and set the video bandwidth to 10 Hz.
 - f) Set the reference level to -50 dBm.
 - g) Set the sweep time to 1 s.
3. Modify the center frequency of the spectrum analyzer according to the frequency parameters listed in Table 2-1. Each time the center frequency is modified, press **Single** and wait for the instrument to perform a single sweep. After the sweep is finished, perform maximum peak search and minimum peak search, then record the results in the test record form.

Table 2-1 Center Frequency Setting of DANL Test

Center Frequency						
50 kHz	1.04 MHz	504 MHz	2.004 GHz	3.004 GHz	4.004 GHz	6.204 GHz

4. Take the average of the maximum peak and minimum peak (add the two values and calculate the average), then normalize it to 1 Hz as the measurement result. That is, use the formula below: **Measurement Result = Average Value – 10 × lg(RBW)**. Wherein, RBW is set to 1 kHz in Step 2. Compare the measurement result with the specification.
5. Keep other settings unchanged and enable the preamplifier of the spectrum analyzer. Repeat Step 3 (ignore the measurement for 50 kHz center frequency) and Step 4, then record the test results.

Test Record Form

Center Frequency	Maximum Peak	Minimum Peak	Average ^[1]	Measurement Result ^[2]	Limit	Pass/Fail
PA off						
50 kHz					9 kHz to 100 kHz: <-120 dBm (typical) 100 kHz~20 MHz: <-135 dBm, <-140 dBm (typical) 20 MHz to 1.5 GHz: <-142 dBm, <-145 dBm (typical) 1.5 GHz to 2.7 GHz: <-140 dBm, <-143 dBm (typical) 2.7 GHz to 3.2 GHz: <-138 dBm, <-141 dBm (typical) 3.2 GHz to 5.5 GHz: <-138 dBm, <-143 dBm (typical) 5.5 GHz to 6.5 GHz: <-136 dBm, <-141 dBm (typical)	
1.04 MHz						
50.04 MHz						
2.004 GHz						
3.004 GHz						
4.004 GHz						
6.204 GHz						
PA on						
1.04 MHz					100 kHz~20 MHz: <-152 dBm, <-160 dBm (typical) 20 MHz to 1.5 GHz: <-162 dBm, <-165 dBm (typical) 1.5 GHz to 2.7 GHz: <-160 dBm, <-163 dBm (typical) 2.7 GHz to 3.2 GHz: <-158 dBm, <-161 dBm (typical) 3.2 GHz to 5.5 GHz: <-156 dBm, <-161 dBm (typical) 5.5 GHz to 6.5 GHz: <-154 dBm, <-159 dBm (typical)	
50.04 MHz						
2.004 GHz						
3.004 GHz						
4.004 GHz						
6.204 GHz						

Note^[1]: Average = (Maximum Peak + Minimum Peak)/2 (dimensionless calculation)

Note^[2]: Measurement Result = Average – 10 × lg1000 = Average - 30 dB

SSB Phase Noise Test

Specification

SSB Phase Noise		
2°C to 30°C, $f_c = 500$ MHz		
Carrier Offset	10 kHz offset	<-106 dBc/Hz, <-108 dBc/Hz (typical)

Test Devices

1. Signal Generator × 1
2. Dual-N Cable × 1
3. Dual-BNC Cable × 1

Test Connection Diagram

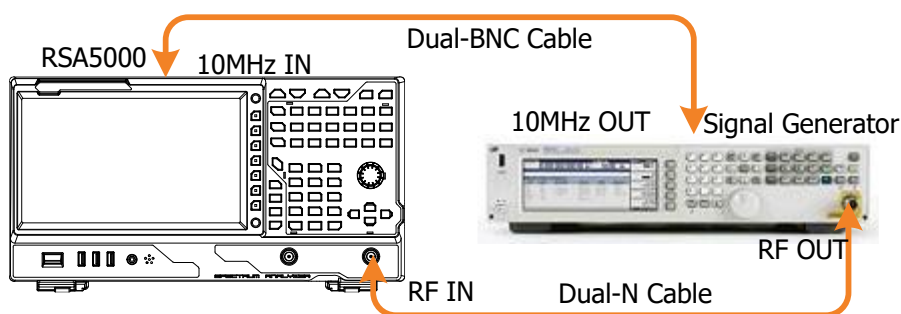

Figure 2-2 SSB Phase Noise Test Connection Diagram

Test Procedures

1. Synchronize the spectrum analyzer and signal generator.
2. Connect the output terminal of the signal generator with the RF input terminal of the spectrum analyzer, as shown in Figure 2-2.
3. Set the signal generator to output a sine waveform with 500 MHz frequency and 0 dBm amplitude.
4. Configure the spectrum analyzer (take 10 kHz offset as an example):
 - a) Set the center frequency to 500 MHz.
 - b) Set the span to 50 kHz.
 - c) Set the input attenuation to 10 dB; and set the reference level to 0 dBm.
 - d) Set the resolution bandwidth to 1 kHz, and set the video bandwidth to 30 Hz.
 - e) Set the trace type to Clear Write.

- f) Set the detector type to Pos Peak.
 - g) Set the sweep time to 10 s.
5. Press **Single** and wait for the instrument to finish a sweep. Then press **Peak** to find the maximum peak.
 6. Set the marker mode to Delta; set the detector type to Average (RMS); set the trace type to Average; set the average number to 5.
 7. Press **Marker** → **Marker Freq**, and input 10 kHz. Press **Single** and wait for the instrument to finish the sweep. Press **Marker Func** → **Band Function** → **Noise**, read the current measurement results, and record the results.
 8. Compare the measurement result with the specification.

Test Record Form

Output Frequency of Signal Generator	Offset	Measurement Result	Limit	Pass/Fail
500 MHz	10 kHz offset		<-106 dBc/Hz, <-108 dBc/Hz (typical)	

Absolute Amplitude Accuracy Test

Specification

Absolute Amplitude Accuracy	
$f_c = 50 \text{ MHz}$, peak detector, PA off, attenuation = 10 dB, input signal level = -10 dBm, 20°C to 30°C	
Uncertainty	<0.3 dB

Test Devices

1. Signal Generator × 1
2. Power Meter × 1
3. Power Sensor × 1
4. Power Meter Connecting Cable × 1
5. Dual-N Cable × 1
6. Dual-BNC Cable × 1
7. Power Divider × 1
8. Dual-N Male Adapter × 1

Test Connection Diagram

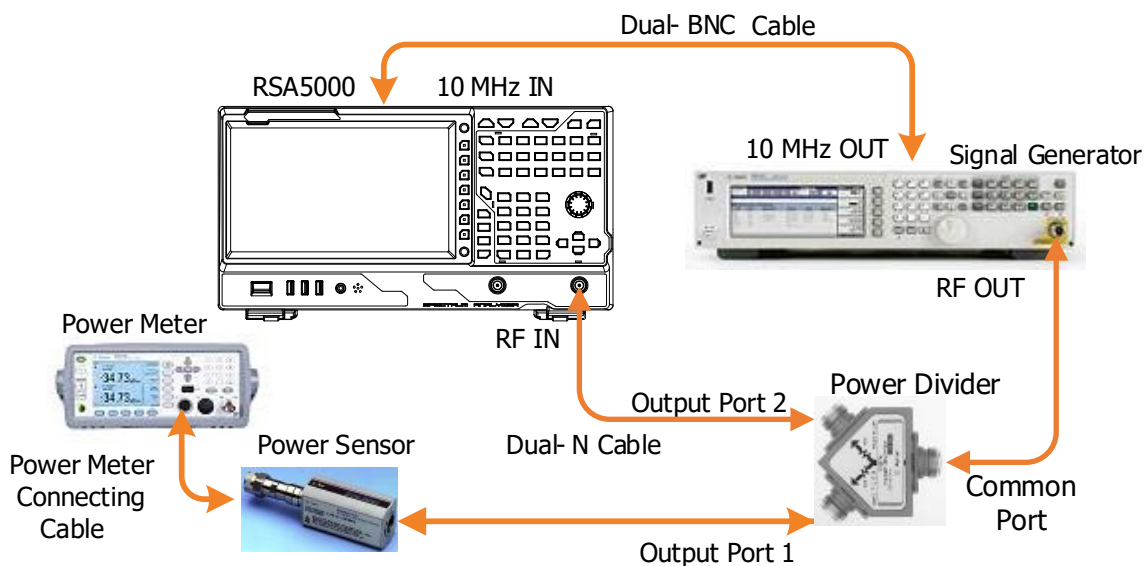

Figure 2-3 Absolute Amplitude Accuracy Test Connection Diagram

Test Procedures

1. Calibrate the power meter:
 - a) Connect the power sensor with the **[REF]** terminal and Channel A of the power meter. Press **Channel** and set the frequency of Channel A to 50 MHz.
 - b) Press **Cal** and enable **Power Ref** in the **Zero/Cal** menu. Press **Zero+Cal** and wait for the calibration to finish; then, observe whether the measurement value of the power meter is a 0 dBm, 50 MHz signal.
 - c) Disable **Power Ref**.
2. Connect the output terminal of the signal generator with the common port of the power divider. Connect the output port 1 of the power divider with the power sensor and connect the output port 2 of the power divider with the spectrum analyzer as shown in Figure 2-3.
3. Set the signal generator to output a sine waveform with 50 MHz frequency and -10 dBm amplitude.
4. Connect the **[10MHz OUT]** terminal of the signal generator with the **[10MHz IN]** terminal on the rear panel of the spectrum analyzer by using a dual-BNC cable to synchronize the two instruments.
5. Configure the spectrum analyzer:
 - a) Set the center frequency to 50 MHz.
 - b) Set the span to 1 MHz.
 - c) Set the reference level to 0 dBm.
 - d) Set the input attenuation to 10 dB.
 - e) Set the resolution bandwidth to 10 kHz.
 - f) Set the sweep time to 100 ms.
6. Measure the output amplitude of the signal generator with power counter. Read and record the power counter measurement result **A1**.
7. Swap the instruments at the output ports of the power divider. Connect the output port 1 of the power divider to the spectrum analyzer and the output port 2 to the power sensor. Record the measurement result of the power meter as **A2**.
8. Calculate the system error of the power divider using the formula: $\text{System Error} = \mathbf{A2} - \mathbf{A1}$.
9. Press **Single** and wait for the instrument to finish a sweep. Then press **Peak** to find the maximum peak. Record the result **A3**.
10. Absolute Amplitude Accuracy = $\mathbf{A2} - (\mathbf{A3} + \text{System Error})$. Compare the measurement result with the specification.

Test Record Form

Power Meter Measurement Value A1	Power Meter Measurement Value A2	Power Divider System Error A2 – A1	Spectrum Analyzer Measurement Value A3	Calculation Result [A2 – (A3 + System Error)]	Limit	Pass/ Fail
					<0.3 dB	

Frequency Response Test

Specification

Frequency Response			
		RSA5032/RSA5032-TG/RSA5032N	RSA5065/RSA5065-TG/RSA506N
attenuation = 10 dB, relative to 50 MHz, 20°C to 30°C			
PA Off	100 kHz to 3.2 GHz	<0.5 dB, <0.3 dB (typical)	<0.5 dB, <0.3 dB (typical)
	3.2 GHz to 6.5 GHz		<0.7 dB, <0.5 dB (typical)
attenuation = 0 dB, relative to 50 MHz, 20°C to 30°C			
PA on	100 kHz to 3.2 GHz	<0.7 dB, <0.3 dB (typical)	<0.7 dB, <0.3 dB (typical)
	3.2 GHz to 6.5 GHz		<0.9 dB, <0.5 dB (typical)

Test Devices

1. Signal Generator × 1
2. Power Meter × 1
3. Power Sensor × 1
4. Power Meter Connecting Cable × 1
5. Dual-N Cable × 1
6. Dual-BNC Cable × 1

Test Connection Diagram

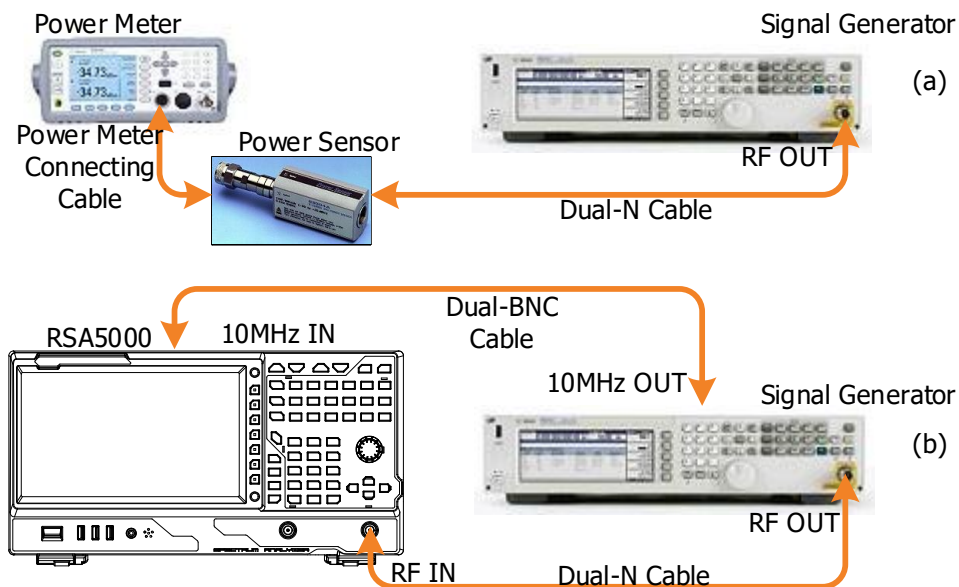

Figure 2-4 Frequency Response Test Connection Diagram

Test Procedures

1. Calibrate the power meter:
 - a) Connect the power sensor with the **[REF]** terminal and Channel A of the power meter. Press **Channel** and set the frequency of Channel A to 50 MHz.
 - b) Press **Cal** and enable **Power Ref** in the **Zero/Cal** menu. Press **Zero+Cal** and wait for the calibration to finish; then, observe whether the measurement value of the power meter is a 0 dBm, 50 MHz signal.
 - c) Disable **Power Ref**.
2. Connect the output terminal of the signal generator with the power sensor, as shown in Figure 2-4 (a).
3. Set the output frequency of the signal generator to 50 MHz; set the amplitude to -10 dBm.
4. Measure the output amplitude of the signal generator by using the power meter and record the measurement result as **Reference Value 1**.
5. Modify the output frequency of the signal generator according to Table 2-2.

Table 2-2 Output Frequency of the Signal Generator

Frequency			
100 kHz	500 MHz	2 GHz	3 GHz
4 GHz	5 GHz	6 GHz	6.499995 GHz

6. Each time the output frequency of the signal generator is modified, the frequency of the power meter is modified accordingly. Measure the amplitude **A1** and record the measurement result. Subtract **Reference Value 1** from **A1** to calculate the **System Error**.
7. Disconnect the signal generator and power sensor. Synchronize the signal generator and spectrum analyzer.
8. Connect the output terminal of the signal generator with the RF input terminal of the spectrum analyzer by using the dual-N cable, as shown in Figure 2-4 (b).
9. Set the output frequency of the signal generator to 50 MHz; set the amplitude to -10 dBm.
10. Configure the spectrum analyzer:
 - a) Set the center frequency to 50 MHz.
 - b) Set the span to 10 kHz.
 - c) Set the reference level to 0 dBm.
 - d) Set the input attenuation to 10 dB.
 - e) Set the resolution bandwidth to 1 kHz.
 - f) Set the sweep time mode to Auto; set the sweep time rule to Accuracy.

- g) Press **Single** and wait for the instrument to finish a sweep. Press **Peak** to find the maximum peak, record the measurement result and take it as **Reference Value 2**.
- 11. Set the output frequency of the signal generator and the center frequency of the spectrum analyzer according to Table 2-2 (the center frequency of the spectrum analyzer corresponds to output frequency of the signal generator).
- 12. Each time the center frequency is modified, press **Single** and wait for the instrument to finish a sweep. Press **Peak** to find the maximum peak, record the measurement result **A2**; subtract **Reference Value 2** from **A2** to calculate the **Global Error** and record the result.
- 13. Use the formula **Frequency Response = |Global Error – System Error|** to calculate the frequency response. Compare the calculation result with the specification.
- 14. Press **Preset** to restore the spectrum analyzer to its factory setting. Enable the PA of the spectrum analyzer. Repeat Step 3-13 (set the output amplitude of the signal generator in Step 3 and Step 9 to -30 dBm) and record the calculation result. At this point, as the PA is enabled, after executing d) in Step 10, the reference level will change to -20 dBm automatically.

Test Record Form

PA Off:

Reference Value 1				Reference Value 2			
Signal Generator Output Frequency	Power Meter Measurement Value A1	Spectrum Analyzer Measurement Value A2	System Error ^[1]	Global Error ^[2]	Frequency Response ^[3]	Limit	Pass/Fail
100 kHz						100 kHz to 3.2 GHz: <0.5 dB, <0.3 dB (typical)	
500 MHz							
2 GHz							
3 GHz							
4 GHz							
5 GHz							
6 GHz							
6.499995 GHz						3.2 GHz to 6.5 GHz: <0.7 dB, <0.5 dB (typical)	

PA On:

Reference Value 1				Reference Value 2			
Signal Generator Output Frequency	Power Meter Measurement Value A1	Spectrum Analyzer Measurement Value A2	System Error ^[1]	Global Error ^[2]	Frequency Response ^[3]	Limit	Pass/Fail
100 kHz						100 kHz to 3.2 GHz: <0.7 dB, <0.3 dB (typical)	
500 MHz							
2 GHz							
3 GHz							
4 GHz							
5 GHz							
6 GHz							
6.499995 GHz						3.2 GHz to 6.5 GHz: <0.9 dB, <0.5 dB (typical)	

Note^[1]: System Error = Power Meter Measurement Value A1 - Reference Value 1

Note^[2]: Global Error = Spectrum Analyzer Measurement Value A2 - Reference Value 2

Note^[3]: Frequency Response = |Global Error - System Error|

Second Harmonic Distortion Test

Specification

Second Harmonic Distortion	
f _c ≥ 50 MHz, input signal level = -20 dBm, attenuation = 10 dB, preamp off.	
Specification	+45 dBm

Test Devices

1. Signal Generator × 1
2. 300 MHz Low-pass Filter × 1
3. 1 GHz Low-pass Filter × 1
4. Dual-BNC Cable × 1
5. N-SMA Cable × 2

Test Connection Diagram

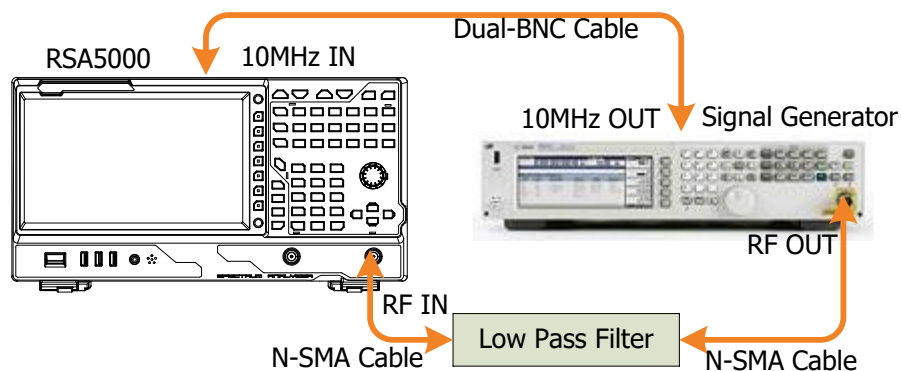

Figure 2-5 Second Harmonic Distortion Test Connection Diagram

Test Procedures

1. Synchronize the signal generator and spectrum analyzer. Connect the output terminal of the signal generator with the 300 MHz low-pass filter. Then connect the filter with the RF input terminal of the spectrum analyzer.
2. Set the output frequency of the signal generator to 300 MHz; set the amplitude to -20 dBm.
3. Configure the spectrum analyzer:
 - a) Set the center frequency to 300 MHz.
 - b) Set the span to 10 kHz.
 - c) Set the maximum mixer level to -20 dBm.
 - d) Set the reference level to -10 dBm.

- e) Set the input attenuation to 10 dB.
 - f) Set the resolution bandwidth to 100 Hz.
 - g) Set the video bandwidth to 100 Hz.
4. Press **Single** and wait for the instrument to finish a sweep. Then press **Peak** to find the maximum peak. Set the marker mode to Delta. Set the center frequency to 600 MHz. Press **Single** and wait for the instrument to finish a sweep. Then press **Peak** and record the delta result.
 5. Use the formula below to calculate the second harmonic distortion. **Second Harmonic Distortion = -20 dBm - Delta** (-20 dBm is the level input into the mixer) Compare the calculation result with the specification.
 6. Press **Preset** to restore the spectrum analyzer to its factory setting. Replace the filter connected with the signal generator with a 1 GHz low-pass filter. Set the output frequency of the signal generator to 1 GHz.
 7. Configure the spectrum analyzer: set the center frequency to 1 GHz and the other parameter settings are the same as that of Step 3.
 8. Press **Single** and wait for the instrument to finish a sweep. Then press **Peak** to find the maximum peak. Set the marker mode to Delta. Set the center frequency to 2 GHz. Press **Single** and wait for the instrument to finish a sweep. Then press **Peak** and record the delta result.
 9. Use the formula below to calculate the second harmonic distortion. **Second Harmonic Distortion = -20 dBm - Delta** (-20 dBm is the level input into the mixer) Compare the calculation result with the specification.

Test Record Form

Output Frequency of Signal Generator	Delta	Calculation Result ^[1]	Limit	Pass/Fail	
300 MHz			>45 dBm		
1 GHz					

Note^[1]: Calculation Result = -20 dBm - Delta (-20 dBm is the level input into the mixer).

TOI Distortion Test

Specification

TOI Distortion	
fc ≥ 50 MHz, two -20 dBm tones at input mixer spaced by 200 kHz, attenuation = 0 dB, preamp off.	
TOI	+11 dBm, +15 dBm (typical)

Test Devices

1. Signal Generator × 2
2. Power Meter × 1
3. Power Sensor × 1
4. Power Meter Connecting Cable × 1
5. Power Divider × 1
6. 300 MHz Low-pass Filter × 1
7. 1 GHz Low-pass Filter × 1
8. Dual-N Cable × 2
9. N-SMA Cable × 2
10. Dual-BNC Cable × 1

Test Connection Diagram

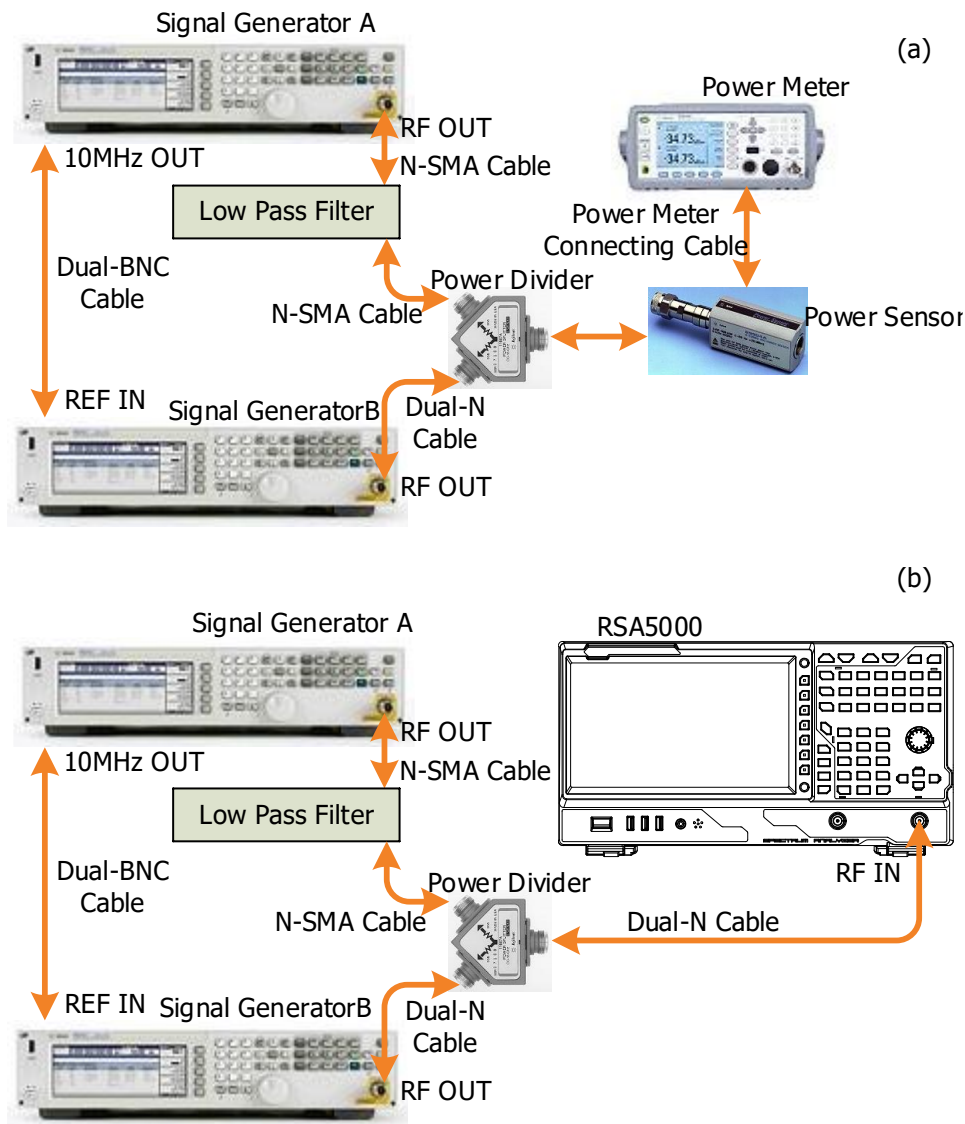

Figure 2-6 TOI Distortion Test Connection Diagram

Test Procedures

1. Calibrate the power meter:
 - a) Connect the power sensor with the **[REF]** terminal and Channel A of the power meter. Press **Channel** and set the frequency of Channel A to 50 MHz.
 - b) Press **Cal** and enable **Power Ref** in the **Zero/Cal** menu. Press **Zero+Cal** and wait for the calibration to finish; then, observe whether the measurement value of the power meter is a 0 dBm, 50 MHz signal.
 - c) Disable **Power Ref**.
2. Synchronize the two signal generators.

Set the output frequency of Signal Generator A to 300 MHz; set the amplitude to -10 dBm.
Set the output frequency of Signal Generator B to 300.2 MHz; set the amplitude to -10 dBm.

3. Connect the output terminal of Signal Generator A to the power divider via a 300 MHz low-pass filter.
4. Connect the output terminal of Signal Generator B with the power divider. Connect the power divider with the power sensor, as shown in Figure 2-6 (a).
5. Press **Channel** on the power meter and set the frequency of Channel A to 300 MHz. Enable the output of Signal Generator A and disable the output of Signal Generator B. Observe the measurement value of the power meter. Adjust the output amplitude of Signal Generator A until the measurement value of the power meter becomes -10 dBm.
6. Press **Channel** on the power meter and set the frequency of Channel A to 300.2 MHz. Disable the output of Signal Generator A and enable the output of Signal Generator B. Observe the measurement value of the power meter. Adjust the output amplitude of Signal Generator B until the measurement value of the power meter becomes -10 dBm.
7. Enable the outputs of the two signal generators. Disconnect the power divider and power sensor; connect the power divider and spectrum analyzer, as shown in Figure Figure 2-6 (b).
8. Configure the spectrum analyzer:
 - a) Set the center frequency to 300 MHz.
 - b) Set the span to 1 kHz.
 - c) Set the CF step to 200 kHz.
 - d) Set the maximum mixer level to -20 dBm.
 - e) Set the input attenuation to 10 dB; and set the reference level to -8 dBm.
 - f) Set the resolution bandwidth to 30 Hz, and set the video bandwidth to 3 Hz.
 - g) Set the peak excursion to 3 dB.
9. Press **Single** and wait for the instrument to finish a sweep. Then press **Peak** to find the maximum peak. Set the marker mode to Delta and reduce the center frequency by 200 kHz. Press **Single** and wait for the instrument to finish a sweep. Then press **Peak** and record the delta result.
10. Use the formula below to calculate the TOI distortion. **TOI Distortion = -20 dBm - Delta/2**. Compare the calculation result with the specification.
11. Exchange the output frequencies of the two signal generators. Set the center frequency of the spectrum analyzer to 300.4 MHz. Press **Single** and wait for the instrument to finish a sweep. Then press **Peak** and record the delta result.
12. Use the formula below to calculate the TOI distortion. **TOI Distortion = -20 dBm - Delta/2**.

Compare the calculation result with the specification.

13. Set the output frequency of Signal Generator A to 1 GHz; set the amplitude to -10 dBm. Set the output frequency of Signal Generator B to 1.0002 GHz; set the amplitude to -10 dBm.
14. Replace the 300 MHz low-pass filter connected with Signal Generator A with a 1 GHz low-pass filter. Repeat Step 4-7 (In Step 5 and Step 6, the frequency of the power is set to 1 GHz and 1.0002 GHz respectively).
15. Keep other settings unchanged. Set the center frequency of the spectrum analyzer to 1 GHz; set the span to 1 kHz. Repeat Step 8-10.
16. Exchange the output settings of the two signal generators. Set the center frequency of the spectrum analyzer to 1.0004 GHz. Press **Single** and wait for the instrument to finish a sweep. Then press **Peak** and record the delta result. Repeat Step 10.

Test Record Form

Center Frequency	Delta	Calculation Result ^[1]	Limit	Pass/Fail	
299.8 MHz			>11 dBm, >+15 dBm (typical)		
300.4 MHz					
999.8 MHz					
1.0004 GHz					

Note^[1]: Calculation Result = -20 dBm - Delta/2 (-20 dBm is the level input into the mixer).

1 dB Gain Compression Test

Specification

1 dB Gain Compression ^[1]	
fc ≥ 50 MHz, attenuation = 0 dB, preamp off	
Specification	0 dBm (nominal)

Note: ^[1] The frequency interval of the two-tone signals should be greater than 10 MHz.

Test Devices

1. Signal Generator × 2
2. Power Meter × 1
3. Power Sensor × 1
4. Power Meter Connecting Cable × 1
5. Power Divider × 1
6. Dual-N Cable × 3
7. Dual-BNC Cable × 1

Test Connection Diagram

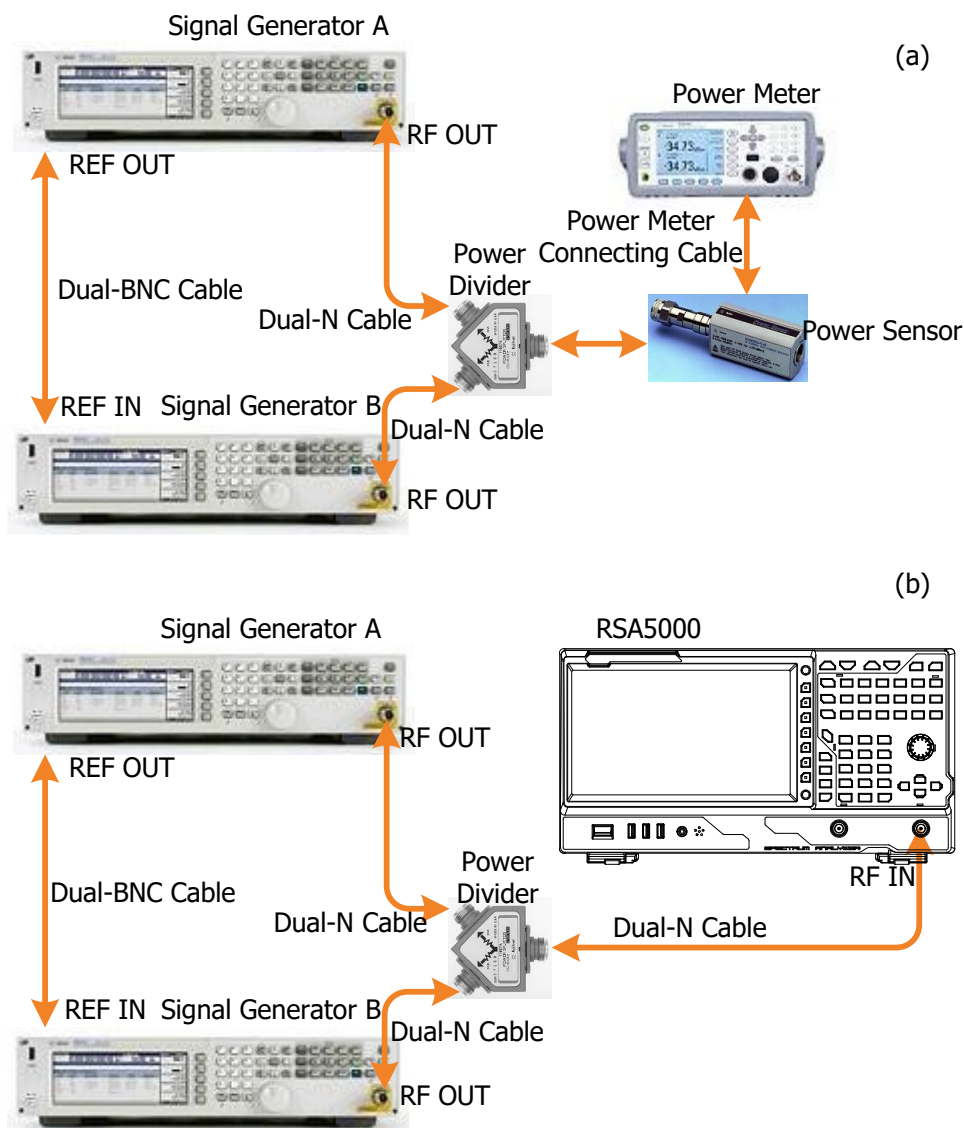

Figure 2-7 1 dB Gain Compression Test Connection Diagram

Test Procedures

1. Calibrate the power meter:
 - a) Connect the power sensor with the **[REF]** terminal and Channel A of the power meter. Press **Channel** and set the frequency of Channel A to 50 MHz.
 - b) Press **Cal** and enable **Power Ref** in the **Zero/Cal** menu. Press **Zero+Cal** and wait for the calibration to finish; then, observe whether the measurement value of the power meter is a 0 dBm, 50 MHz signal.
 - c) Disable **Power Ref**.
2. Synchronize the two signal generators. Connect the outputs of the two signal generators with the power divider. Then connect the power divider with the power sensor, as shown in Figure 2-7 (a).

3. Set the signal generators:
Set the output frequency of Signal Generator A to 50 MHz; set the amplitude to -20 dBm.
Set the output frequency of Signal Generator B to 65 MHz; set the amplitude to 0 dBm.
4. Press **Channel** on the power meter and set the frequency of Channel A to 50 MHz.
Enable the output of Signal Generator A and disable the output of Signal Generator B. Observe the measurement value of the power meter. Adjust the output amplitude of Signal Generator A until the readout value of the power meter becomes -20 dBm.
5. Press **Channel** on the power meter and set the frequency of Channel A to 65 MHz.
Disable the output of Signal Generator A and enable the output of Signal Generator B. Observe the measurement value of the power meter. Adjust the output amplitude of Signal Generator B until the readout value of the power meter becomes 0 dBm.
6. Disconnect the power divider and power sensor; connect the power divider and spectrum analyzer, as shown in Figure Figure 2-7 (b).
7. Enable the output of Signal Generator A and disable the output of Signal Generator B.
8. Configure the spectrum analyzer:
 - a) Set the center frequency to 50 MHz.
 - b) Set the span to 100 kHz.
 - c) Set the reference level to 0 dBm.
 - d) Set the input attenuation to 0 dB.
 - e) Set the resolution bandwidth to 1 kHz.
 - f) Set the sweep time mode to Auto; set the sweep time rule to Accuracy.
9. Press **Single** and wait for the instrument to finish a sweep. Press **Peak** to measure the current peak, record the measurement result as **A1**.
10. Enable the outputs of the two signal generators. Press **Single** and wait for the instrument to finish a sweep. Press **Peak** to measure the peak at 50 MHz, record the measurement result as **A2**.
11. **Delta = A1 - A2**. Record the delta result.

Test Record Form

Output Amplitude of Signal Generator B	Measurement Result A1	Measurement Result A2	Calculation Result ^[1]	Limit	Pass/Fail
0 dBm				<1 dBm	

Note^[1]: Calculation Result = A1 - A2.

Input Attenuation Switching Uncertainty Test

Specification

Input Attenuation Switching Uncertainty	
fc = 50 MHz, relative to 10 dB, PA off, 20°C to 30°C	
Switching Uncertainty	<0.3 dB

Test Devices

1. Signal Generator × 1
2. Power Meter × 1
3. Power Sensor × 1
4. Power Meter Connecting Cable × 1
5. Program-controlled Attenuator:
 - Attenuator/Switch Driver × 1
 - Step Attenuator (Step: 1 dB) × 1
 - Step Attenuator (Step: 10 dB) × 1
 - Attenuator Interconnect Kit × 1
6. Dual-N Cable × 2

Test Connection Diagram

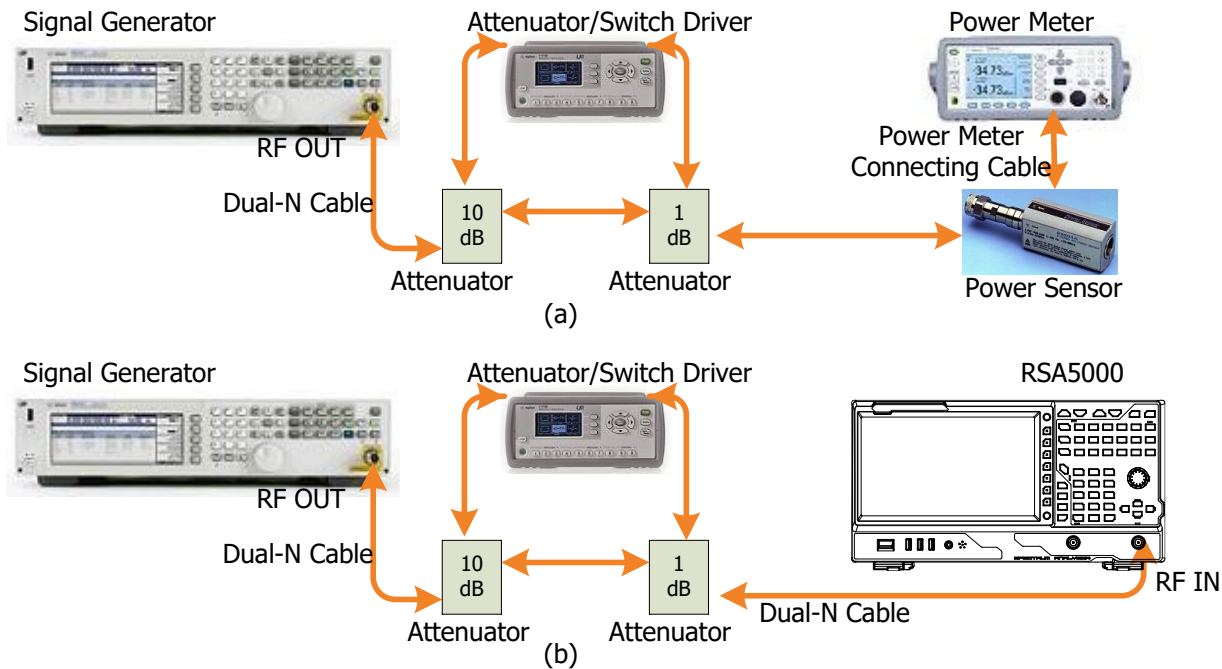

Figure 2-8 Input Attenuation Switching Uncertainty Test Connection Diagram

Test Procedures

- Calibrate the power meter:
 - Connect the power sensor with the **[REF]** terminal and Channel A of the power meter. Press **Channel** and set the frequency of Channel A to 50 MHz.
 - Press **Cal** and enable **Power Ref** in the **Zero/Cal** menu. Press **Zero+Cal** and wait for the calibration to finish; then, observe whether the measurement value of the power meter is a 0 dBm, 50 MHz signal.
 - Disable **Power Ref**.
- Connect the output terminal of the signal generator with the program-controlled attenuator; then, connect the program-controlled attenuator with the power sensor, as shown in Figure 2-8 (a).
- Set the output frequency of the signal generator to 50 MHz; set the amplitude to +10 dBm.
- Set the attenuation of the program-controlled attenuator to 20 dB and measure the amplitude with the power meter. Use the formula below to calculate the system error reference value. **System Error Reference Value = Power Meter Measurement Value - (+10 dBm – 20 dB)**. Record the calculation result in the test record form.
- Modify the attenuation of the program-controlled attenuator according to the **Test Record Form** (keep other parameters unchanged). Each time the attenuation is modified, measure the

- amplitude with the power meter. Use the formula below to calculate the system error. **System Error = Power Meter Measurement Value - (+10 dBm - Attenuation of the Program-controlled Attenuator) - System Error Reference Value.** Record the calculation result in the test record form.
6. Disconnect the program-controlled attenuator and the power sensor. Connect the output of the program-controlled attenuator to the RF input terminal of the spectrum analyzer, as shown in Figure 2-8 (b).
 7. Set the attenuation of the program-controlled attenuator to 20 dB.
 8. Configure the spectrum analyzer:
 - a) Set the center frequency to 50 MHz.
 - b) Set the span to 10 kHz.
 - c) Set the reference level to 0 dBm.
 - d) Set the input attenuation to 10 dB.
 - e) Set the resolution bandwidth to 1 kHz, and set the video bandwidth to 10 Hz.
 - f) Set the sweep time mode to Auto; set the sweep time rule to Accuracy.
 9. Press **Single** and wait for the instrument to finish a sweep. Press **Peak** to find the maximum peak. Use the formula below to calculate the global error reference value. **Global Error Reference Value = Maximum Peak of the Spectrum Analyzer - (+10 dBm - 20 dB).** Record the calculation result in the test record form.
 10. Set the attenuation of the program-controlled attenuator, the reference level of the spectrum analyzer, and the attenuation of the internal attenuator according to the **Test Record Form.** For each group of settings, press **Single** and wait for the instrument to finish a sweep. Press **Peak** to find the maximum peak. Use the formula below to calculate the global error. **Global Error = Maximum Peak of the Spectrum Analyzer - (+10 dBm - Attenuation of the Program-controlled Attenuator) - Global Error Reference Value.** Record the calculation result in the test record form.
 11. Use the formula **Uncertainty = |Global Error - System Error|** to calculate the uncertainty. Compare the calculation result with the specification.

Test Record Form

System Error Reference Value							
Global Error Reference Value							
Reference Level	Internal Attenuator	Program-controlled Attenuator	System Error ^[1]	Global Error ^[2]	Uncertainty ^[3]	Limit	Pass/Fail
-10 dBm	0 dB	30 dB				<0.3 dB	
-9 dBm	1 dB	29 dB					
-8 dBm	2 dB	28 dB					
-7 dBm	3 dB	27 dB					
-6 dBm	4 dB	26 dB					
-5 dBm	5 dB	25 dB					
-4 dBm	6 dB	24 dB					
-3 dBm	7 dB	23 dB					
-2 dBm	8 dB	22 dB					
-1 dBm	9 dB	21 dB					
0 dBm	10 dB	20 dB					
1 dBm	11 dB	19 dB					
2 dBm	12 dB	18 dB					
3 dBm	13 dB	17 dB					
4 dBm	14 dB	16 dB					
5 dBm	15 dB	15 dB					
6 dBm	16 dB	14 dB					
7 dBm	17 dB	13 dB					
8 dBm	18 dB	12 dB					
9 dBm	19 dB	11 dB					
10 dBm	20 dB	10 dB					
11 dBm	21 dB	9 dB					
12 dBm	22 dB	8 dB					
13 dBm	23 dB	7 dB					
14 dBm	24 dB	6 dB					
15 dBm	25 dB	5 dB					
16 dBm	26 dB	4 dB					
17 dBm	27 dB	3 dB					
18 dBm	28 dB	2 dB					
19 dBm	29 dB	1 dB					
20 dBm	30 dB	0 dB					

Note^[1]: System Error = Measurement Value of the Power Meter - (+10 dBm - Attenuation of the Program-controlled Attenuator) - System Error Reference Value

Note^[2]: Global Error = Maximum Peak of the Spectrum Analyzer - (+10 dBm - Attenuation of the Program-controlled Attenuator) - Global Error Reference Value

Note^[3]: Uncertainty = |Global Error - System Error|

10 MHz Reference Output Accuracy Test

Specification

10 MHz Reference Output Accuracy	
Specification	Aging rate ^[1] × time since last calibration ^[2] + temperature stability ^[3] + calibration accuracy ^[4]

Note^[1]: Aging rate: <1 ppm/year

Note^[2]: The instrument will be calibrated before leaving factory.

Note^[3]: Temperature stability: <0.5 ppm

Note^[4]: Initial calibration accuracy <1 ppm

Test Devices

1. Frequency Counter × 1
2. Dual-BNC Cable × 1

Test Connection Diagram

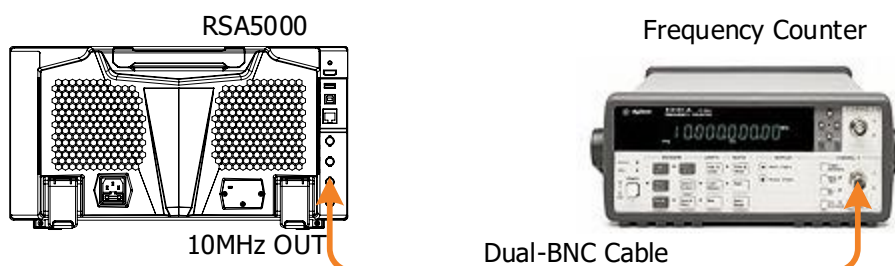

Figure 2-9 10 MHz Reference Output Accuracy Test Connection Diagram

Test Procedures

1. Connect the **[10 MHz OUT]** terminal on the rear panel of the spectrum analyzer with the frequency counter, as shown in Figure 2-9.
2. Compare the measurement result of the frequency counter with the specification.

Test Record Form

Frequency Counter Measurement Result	Output Accuracy ^[1]	Limit	Pass/Fail
		<10 MHz × (1 ppm × time since last calibration + 0.5 ppm + 1 ppm)	

Note^[1]: Output Accuracy = |Frequency Counter Measurement Result - 10 MHz|

Appendix Test Record Form

RIGOL RSA5000 Series Real-Time Spectrum Analyzer Performance Verification Test Record Form

Model: _____ Tested by: _____ Test Date: _____

Displayed Average Noise Level (DANL) Test:

Center Frequency	Maximum Peak	Minimum Peak	Average ^[1]	Measurement Result ^[2]	Limit	Pass/Fail
PA Off						
50 kHz					9 kHz to 100 kHz: <-120 dBm (typical) 100 kHz~20 MHz: <-135 dBm, <-140 dBm (typical) 20 MHz to 1.5 GHz: <-142 dBm, <-145 dBm (typical) 1.5 GHz to 2.7 GHz: <-140 dBm, <-143 dBm (typical) 2.7 GHz to 3.2 GHz: <-138 dBm, <-141 dBm (typical) 3.2 GHz to 5.5 GHz: <-138 dBm, <-143 dBm (typical) 5.5 GHz to 6.5 GHz: <-136 dBm, <-141 dBm (typical)	
1.04 MHz						
50.04 MHz						
2.004 GHz						
3.004 GHz						
4.004 GHz						
6.204 GHz						
PA On						
1.04 MHz					100 kHz~20 MHz: <-152 dBm, <-160 dBm (typical) 20 MHz to 1.5 GHz: <-162 dBm, <-165 dBm (typical) 1.5 GHz to 2.7 GHz: <-160 dBm, <-163 dBm (typical) 2.7 GHz to 3.2 GHz: <-158 dBm, <-161 dBm (typical) 3.2 GHz to 5.5 GHz: <-156 dBm, <-161 dBm (typical) 5.5 GHz to 6.5 GHz: <-154 dBm, <-159 dBm (typical)	
50.04 MHz						
2.004 GHz						
3.004 GHz						
4.004 GHz						
6.204 GHz						

Note^[1]: Average = (Maximum Peak + Minimum Peak)/2 (dimensionless calculation)

Note^[2]: Measurement Result = Average – 10 × lg1000 = Average - 30 dB

SSB Phase Noise Test:

Output Frequency of Signal Generator	Offset	Measurement Result	Limit	Pass/Fail
500 MHz	10 kHz offset		<-106 dBc/Hz, <-108 dBc/Hz (typical)	

Absolute Amplitude Accuracy Test:

Power Meter Measurement Value A1	Power Meter Measurement Value A2	Power Divider System Error A2 – A1	Spectrum Analyzer Measurement Value A3	Calculation Result [A2 – (A3 + System Error)]	Limit	Pass/Fail
					<0.3 dB	

Frequency Response Test (PA Off):

Reference Value 1				Reference Value 2			
Signal Generator Output Frequency	Power Meter Measurement Value A1	Spectrum Analyzer Measurement Value A2	System Error ^[1]	Global Error ^[2]	Frequency Response ^[3]	Limit	Pass/Fail
100 kHz						100 kHz to 3.2 GHz: <0.5 dB, <0.3 dB (typical)	
500 MHz							
2 GHz							
3 GHz							
4 GHz							
5 GHz							
6 GHz						3.2 GHz to 6.5 GHz: <0.7 dB, <0.5 dB (typical)	
6.499995 GHz							

Frequency Response Test (PA On):

Reference Value 1				Reference Value 2			
Signal Generator Output Frequency	Power Meter Measurement Value A1	Spectrum Analyzer Measurement Value A2	System Error ^[1]	Global Error ^[2]	Frequency Response ^[3]	Limit	Pass/Fail
100 kHz						100 kHz to 3.2 GHz: <0.7 dB, <0.3 dB (typical)	
500 MHz							
2 GHz							
3 GHz							
4 GHz							
5 GHz							
6 GHz							
6.499995 GHz						3.2 GHz to 6.5 GHz: <0.9 dB, <0.5 dB (typical)	

Note^[1]: System Error = Power Meter Measurement Value A1 - Reference Value 1

Note^[2]: Global Error = Spectrum Analyzer Measurement Value A2 - Reference Value 2

Note^[3]: Frequency Response = |Global Error - System Error|

Second Harmonic Distortion Test:

Output Frequency of Signal Generator	Delta	Calculation Result ^[1]	Limit	Pass/Fail
300 MHz			>45 dBm	
1 GHz				

Note^[1]: Calculation Result = -20 dBm - Delta (-20 dBm is the level input into the mixer).

TOI Distortion Test:

Center Frequency	Delta	Calculation Result ^[1]	Limit	Pass/Fail
299.8 MHz			>11 dBm, >+15 dBm (typical)	
300.4 MHz				
999.8 MHz				
1.0004 GHz				

Note^[1]: Calculation Result = -20 dBm - Delta/2 (-20 dBm is the level input into the mixer).

1 dB Gain Compression Test:

Output Amplitude of Signal Generator B	Measurement Result A1	Measurement Result A2	Calculation Result ^[1]	Limit	Pass/Fail
0 dBm				<1 dBm	

Note^[1]: Calculation Result = A1 - A2.

Input Attenuation Switching Uncertainty Test:

System Error Reference Value							
Global Error Reference Value							
Reference Level	Internal Attenuator	Program-controlled Attenuator	System Error ^[1]	Global Error ^[2]	Uncertainty ^[3]	Limit	Pass/Fail
-10 dBm	0 dB	30 dB				<0.3 dB	
-9 dBm	1 dB	29 dB					
-8 dBm	2 dB	28 dB					
-7 dBm	3 dB	27 dB					
-6 dBm	4 dB	26 dB					
-5 dBm	5 dB	25 dB					
-4 dBm	6 dB	24 dB					
-3 dBm	7 dB	23 dB					
-2 dBm	8 dB	22 dB					
-1 dBm	9 dB	21 dB					
0 dBm	10 dB	20 dB					
1 dBm	11 dB	19 dB					
2 dBm	12 dB	18 dB					
3 dBm	13 dB	17 dB					
4 dBm	14 dB	16 dB					
5 dBm	15 dB	15 dB					
6 dBm	16 dB	14 dB					
7 dBm	17 dB	13 dB					
8 dBm	18 dB	12 dB					
9 dBm	19 dB	11 dB					
10 dBm	20 dB	10 dB					
11 dBm	21 dB	9 dB					
12 dBm	22 dB	8 dB					
13 dBm	23 dB	7 dB					
14 dBm	24 dB	6 dB					
15 dBm	25 dB	5 dB					
16 dBm	26 dB	4 dB					
17 dBm	27 dB	3 dB					
18 dBm	28 dB	2 dB					
19 dBm	29 dB	1 dB					

20 dBm	30 dB	0 dB						
--------	-------	------	--	--	--	--	--	--

Note^[1]: System Error = Measurement Value of the Power Meter - (+10 dBm - Attenuation of the Program-controlled Attenuator) - System Error Reference Value

Note^[2]: Global Error = Maximum Peak of the Spectrum Analyzer - (+10 dBm - Attenuation of the Program-controlled Attenuator) - Global Error Reference Value

Note^[3]: Uncertainty = |Global Error - System Error|

10 MHz Reference Output Accuracy Test:

Frequency Counter Measurement Result	Output Accuracy ^[1]	Limit	Pass/Fail
		<10 MHz × (1 ppm × time since last calibration + 0.5 ppm + 1 ppm)	

Note^[1]: Output Accuracy = |Frequency Counter Measurement Result - 10 MHz|