



RIGOL

PCA3000 Series

Current Probe

User Guide

Apr.2026



Guaranty and Declaration

Copyright

© 2026 RIGOL TECHNOLOGIES CO., LTD. All Rights Reserved.

Trademark Information

RIGOL® is the trademark of RIGOL TECHNOLOGIES CO., LTD.

Notices

- RIGOL products are covered by P.R.C. and foreign patents, issued and pending.
- RIGOL reserves the right to modify or change parts of or all the specifications and pricing policies at the company's sole decision.
- Information in this publication replaces all previously released materials.
- Information in this publication is subject to change without notice.
- RIGOL shall not be liable for either incidental or consequential losses in connection with the furnishing, use, or performance of this manual, as well as any information contained.
- Any part of this document is forbidden to be copied, photocopied, or rearranged without prior written approval of RIGOL.

Product Certification

RIGOL guarantees that this product conforms to the national and industrial standards in China as well as the ISO9001:2015 standard and the ISO14001:2015 standard. Other international standard conformance certifications are in progress.

Contact Us

If you have any problem or requirement when using our products or this manual, please contact RIGOL.

E-mail: service@rigol.com

Website: <http://www.rigol.com>

Section	Description	Page
1	Safety Requirement	1
1.1	General Safety Summary	1
1.2	Safety Notices and Symbols	2
1.3	Environmental Considerations	3
2	Document Overview	4
3	General Inspection	5
4	Safety Precautions	6
5	Current Probe Overview	10
5.1	Probe Parts Overview	10
5.2	Parts Introductions	11
6	To Use the Current Probe	13
6.1	Preparations for Measurement	13
6.2	Demagnetizing and Zero Adjustment	13
6.3	Measurement Procedure	14
6.4	Precautions for Measurement	16
7	Specifications	20
8	Appendix	22
8.1	Appendix 1 Amplitude-Frequency Characteristics	22
8.2	Appendix 2 Relation between Max Input Current and Frequency	22
9	Care and Cleaning	23
10	Warranty	24

1 Safety Requirement

1.1 General Safety Summary

Read the following safety precautions before using the product to avoid personal injury and to prevent damage to this product or any equipment connected to this product.

To prevent possible hazards, be sure to use this product in accordance with the regulations.

- **Connect or Disconnect the Equipment Properly.**

Connect the probe output terminal to the measuring instrument before the probe is connected to the circuit under test. Disconnect the probe input terminal from the circuit under test before disconnecting the probe from the instrument.

- **Observe All Terminal Ratings.**

To avoid fire or electric shock, please observe all ratings and markings on the product. Before making any connections to the product, consult the User Guide of the product for more details about ratings.

- **Use the Product only in Specified Measurement Category.**

The probe only applies to circuits not directly connected to the mains (CAT I). It is not applicable to CAT II, CAT III, or CAT IV measurement.

- **Check the Equipment Status Periodically.**

Check the physical status of the probe and its accessories, including the cables, interfaces, or any visible damage or wear. Do not use the probe with damaged, cracked, or defective cable. Stop using it with suspected failures.

- **Do Not Operate with Suspected Failures.**

If you suspect that there is damage to the product, have it inspected by RIGOL authorized personnel before further operations. Any maintenance, adjustment or replacement especially to circuits or accessories must be performed by RIGOL authorized personnel.

- **Avoid Exposed Circuitry.**

Do not touch exposed circuits and components after the power is connected.

- **ESD Protection.**

Electrostatic Discharge (ESD) may cause damage to the instrument. Therefore, perform tests in an ESD Protected Area (EPA) whenever possible. Before connecting a cable to the instrument, briefly ground its inner and outer conductors to release static electricity.

- **Do Not Operate in Wet Conditions.**

For indoor use only. To avoid short circuit inside the instrument or electric shock, never use the product in a humid environment.

- **Do Not Operate in an Explosive Atmosphere.**

To avoid personal injuries or damage to the instrument, never operate the instrument in an explosive atmosphere.

- **Keep Product Surfaces Dry and Clean.**

1.2 Safety Notices and Symbols

Safety Notices in this Manual:



WARNING

Indicates a potentially hazardous situation or practice which, if not avoided, will result in serious injury or death.



CAUTION

Indicates a potentially hazardous situation or practice which, if not avoided, could result in damage to the product or loss of important data.

Safety Notices on the Product:

- **DANGER**

It calls attention to an operation, if not correctly performed, could result in injury or hazard immediately.

- **WARNING**

It calls attention to an operation, if not correctly performed, could result in potential injury or hazard.

- **CAUTION**

It calls attention to an operation, if not correctly performed, could result in damage to the product or other devices connected to the product.

Safety Symbols on the Product:



**Hazardous
Voltage**



Safety Warning



**Protective Earth
Terminal**

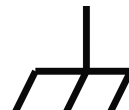

Chassis Ground



Test Ground

1.3 Environmental Considerations

The following symbol indicates that this product complies with the WEEE Directive 2012/19/EU.



The equipment may contain substances that could be harmful to the environment or human health. To avoid the release of such substances into the environment and avoid harm to human health, we recommend you to recycle this product appropriately to ensure that most materials are reused or recycled properly. Please contact your local authorities for disposal or recycling information.

You can click on the following link <https://www.rigol.com/intl/services/environmental-protection-statement.html> to download the latest version of the RoHS&WEEE certification file.

2 Document Overview

This manual gives you a quick overview of the technical specifications and basic operation methods of the PCA3000 Series Active Probe.



TIP

For the latest version of this manual, download it from RIGOL official website (<http://www.rigol.com>).

Publication Number

UGE42100-1110

Content Conventions in this Manual

The PCA3000 Series Active Probe includes the following model.

Model	Bandwidth
PCA3030	50 MHz (-3 dB)
PCA3031	120 MHz (-3 dB)

3 General Inspection

1. Inspect the packaging

If the packaging has been damaged, do not dispose the damaged packaging or cushioning materials until the shipment has been checked for completeness and has passed both electrical and mechanical tests.

The consigner or carrier shall be liable for the damage to the instrument resulting from shipment. RIGOL would not be responsible for free maintenance/rework or replacement of the instrument.

2. Check the probe

In case of any mechanical damage, missing parts, or failure in passing the electrical and mechanical tests, contact your RIGOL sales representative.

3. Check the accessories

Please check the accessories according to the packing lists. If the accessories are damaged or incomplete, please contact your RIGOL sales representative.

4 Safety Precautions

DANGER

1. Do not measure around a bare conductor. Doing so may result in short-circuit or electric shock. Take measurements at a location on an insulated wire where there is sufficient insulation for the circuit voltage.
2. Refer to *Appendix 2 Relation between Max Input Current and Frequency* when measuring current that includes a high-frequency component. Never measure any current that exceeds the rated current.
3. Using the device in high-frequency or strong magnetic field may cause the device to become abnormally hot, resulting in fire, equipment damage, or burns (see *Specifications*).
4. Observe the following to avoid electric shock and short circuit.
 - a. Connect the probe to the waveform measurement instrument first, and then connect the probe to the active cable to be measured.
 - b. When the sensor is opened, do not short circuit the conductor being measured.
 - c. Be careful to avoid damaging the insulation surface while taking measurements.
 - d. Before clamping the conductor being measured, make sure that the insulation on the conductor is undamaged. Also, take care not to damage the insulation when clamping the conductor. Any damage to the insulation could cause an electric shock.
 - e. To prevent fire, burns, or damage of the DUT, pay attention to the following items when measuring high-frequency current or current that has high-frequency components:
 - Eddy current loss may cause heating of the sensor head.
 - Dielectric heating may cause heating of cord insulation and other materials.
 - f. This device should only be connected to the secondary side of a breaker, so the breaker can prevent an accident if a short circuit occurs. Connections should

never be made to the primary side of a breaker, because unrestricted current flow could cause a serious accident if a short circuit occurs.

- g.** Be sure to observe all operating precautions for the waveform measurement instrument and other measurement instruments to which this device is connected.
- h.** When using a measurement instrument that does not provide isolation between its input terminals, chassis, or other input terminals, please pay attention to the following points. As shown in the following figure, if a signal is applied to an input terminal other than that to which this device is connected, do not connect the ground terminal of the signal to any non-ground potential. Otherwise, short-circuit current will flow through the current probe from the ground terminal, which could cause an electrical accident or damage.

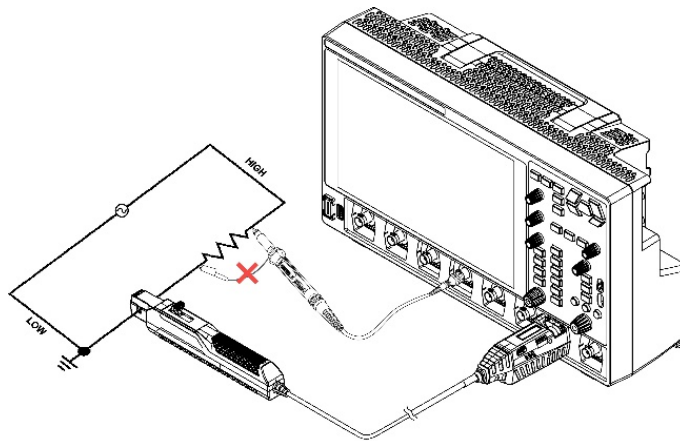

WARNING

- 1.** Keep the device dry, and do not take measurements with wet hands. This may cause an electric shock.
- 2.** Do not perform demagnetization operation on the waveform measurement instrument while the conductor being measured is clamped onto the probe. Doing so could damage the circuitry or cause an accident that might result in injury or death.

3. Ensure that the input does not exceed the maximum rated current to avoid device damage, short-circuiting and electric shock resulting from overheating.
4. To avoid electric shock when measuring live lines, wear appropriate protective gear, such as insulated rubber gloves, boots and a safety helmet.

CAUTION

1. To avoid damage to the device, protect it from vibration or shock during transport and handling, and be especially careful to avoid falling.
2. This probe should be installed and operated indoors only, at the ambient temperature between 0°C and 40°C, in the humidity of 80%RH or less.
3. Do not store or use the device in a place where it could be exposed to direct sunlight, high temperature, humidity, or condensation. Under such conditions, the device may be damaged and insulation may deteriorate so that it no longer meets specifications.
4. This device is not designed to be entirely water-proof or dust-proof. To avoid damage, do not use it in a wet or dusty environment.
5. The sensor head is a precision assembly which includes a molded component, a ferrite core, and a Hall effect element. It may be damaged if subjected to sudden changes in ambient temperature, or mechanical strain or shock, and therefore great care should be exercised in handling it.
6. The gear mating surface of the sensor head is precision ground, and should be treated with care. If the surface is scratched, performance may be impaired.
7. Measurements are degraded by dirt on the gear mating surface of the sensor head, so keep the surface clean with a soft cloth.
8. Foreign substances such as dust on the contact surface of the sensor head can cause resonant sound (refer to the introduction about 5 in the later section) and degrade measurement, so it should be cleaned with a soft cloth.
9. Do not bend or pull the cables to avoid damaging them.

- 10.** Do not apply a static electricity or other source of high voltage to the sensor.
Doing so may damage its internal Hall elements and circuitry.
- 11.** To clean the device, wipe it gently with a soft cloth moistened with water or mild detergent. Never use solvents such as benzene, alcohol, acetone, ether, ketones, thinners or gasoline, as they can deform and discolor the case.
- 12.** When the power is on, keep the sensor closed, except when clamping it onto the conductor to be measured. Otherwise, the gear mating surface of the magnetic core section can be scratched when the sensor is open.
- 13.** Keep the sensor head closed when not in use, to avoid accumulating dust or dirt on the gear mating surface, which could affect its clamp performance.
- 14.** Avoid stepping on or pinching the cable, which could damage the cable insulation.
- 15.** Keep the cables away from heat sources, as bare conductors could be exposed if the insulation melts.

NOTE

Correct measurement may be impossible in the presence of strong magnetic fields, such as near transformers and high-current conductors, or in the presence of strong electromagnetic fields such as near radio transmitters.

5 Current Probe Overview

This device can be directly connected to a BNC input connector of a waveform measurement instrument. Once being clamped on a conductor to be measured through the sensor head, it can capture the current waveform easily.

Main Features:

- Highly accurate current detection
- Easy current measurement
- Broadband frequency characteristics
PCA3030: DC to 50 MHz (-3 dB)
PCA3031: DC to 120 MHz (-3 dB)
- Compact design, available to measure low current level
- Easy warning function at excessive input
- Unique thin film Hall effect element

5.1 Probe Parts Overview

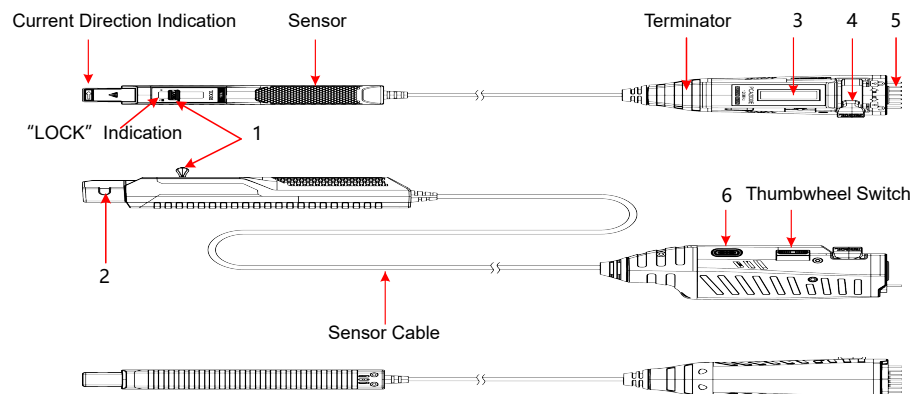

Figure 5.1 PCA3000 Series Probe Parts

For the parts from 1 to 6 noted in the above figure, please refer to [Parts Introductions](#).

NOTE

In the above figure, the Terminator is connected to the waveform measurement instrument via the output connector. The Terminator will provide power to the current probe when the waveform measurement instrument is powered on.

5.2 Parts Introductions

1. Opening lever

It is used to open and lock the current sensor. You are recommended to lock the current sensor when measuring the conductor to avoid danger.

There are Lock and Unlock indications on one side of the opening lever. The on/off status of the current sensor is related to the position of the opening lever.

- When the opening lever is in the Unlock position, the current sensor is open and at this point, the conductor to be measured can be connected to the current sensor;
- When the opening lever is in the Lock position (with the lever pushed to the top), the current sensor is locked.

2. Sensor head

It is used to clamp the conductor under measurement to carry out the actual current measurement. It is a precision assembly that includes a molded component, a ferrite core, and a Hall effect element. It may be damaged if subjected to sudden changes in ambient temperature, or mechanical strain or shock, and therefore great care should be exercised in handling it.

3. Probe Display

When the probe is powered on, it displays the probe information. You can set probe demagnetizing, probe attenuation ratio, and probe bias through the thumbwheel switch.

- **Demagnetizing**

Toggle the thumbwheel switch to select demagnetization. Press the switch to start the probe demagnetizing function. A demagnetizing completion icon will be displayed when demagnetizing is finished.

- **Probe Ratio**

The probe provides two probe ratios: 10X and 1X. By default, the probe ratio is 10X. Toggle the thumbwheel switch to select Probe Ratio, and press the switch to toggle between 10X and 1X.

- **Probe Bias**

Toggle the thumbwheel switch to select Probe Bias. Press the switch to enter the probe bias setting mode. In this mode, you can toggle the switch up or down to

adjust the probe bias value. Press the switch again to exit the probe bias setting mode.

4. BNC lever

It is used to lock and unlock the connection to the measurement instruments. For locking operation, first move the lever to the unlocked position. After fully inserting the probe BNC connector into the oscilloscope, move the lever to the locked position to ensure a secure connection.

For unlocking operation, first move the lever back to the unlocked position. Once the lever has fully returned, the probe can be smoothly removed.

5. Output connector

The current waveform of the conductor under measurement is output at a constant gain via this connector to the waveform measurement instrument. This connector can be connected to the BNC input connector of the waveform measurement instrument.

NOTE

- Since the output impedance of the current probe is $35\ \Omega$, the current probe must be connected to a waveform measurement instrument that has an input impedance of at least $1\ \text{M}\Omega$. Accurate measurement is not possible with waveform measurement instrument that has an input impedance of $50\ \Omega$.
- If using BNC-banana plug adapters or similar connectors to connect to input terminals other than BNC connectors, make sure the polarity is correct in connection.

6. Type-C interface

To power the probe, use a PD standard adapter that supports a 12V output with the power greater than 35W. The probes in this manual do not support external power supply.

6 To Use the Current Probe

Before using the current probe, make sure to refer to *Safety Precautions*.

6.1 Preparations for Measurement

1. Prepare a set of waveform measurement instrument.
2. Connect the waveform measurement instrument to the AC power source.
3. Connect the output connector of the current probe to the input terminal of the waveform measurement instrument.

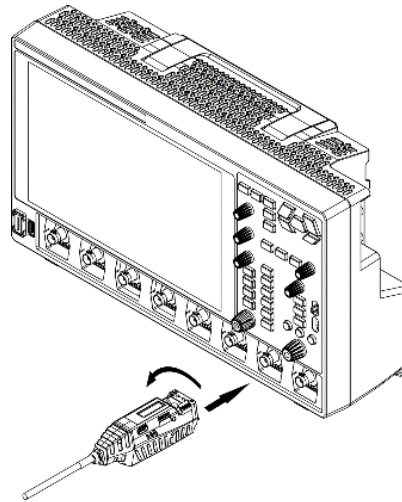

4. Turn on the current probe and wait at least 30 minutes. Immediately after it is powered on, zero drift occurs obviously due to the warm-up and other factors. To ensure the accurate measurement, wait for at least a 30-minute warm-up after turning on the current probe before performing the measurement.

6.2 Demagnetizing and Zero Adjustment

1. Enter the Probe interface on the measurement instrument, and perform demagnetization and probe calibration.
2. Set the input coupling of the waveform measurement instrument to DC.

CAUTION

- When disconnecting the output connector from the waveform measurement instrument, be sure to release the lock before pulling out the connector. Forcibly pulling out the connector without releasing the lock or pulling the cable can damage the terminator.
 - If using BNC-banana plug adapters or similar connectors to connect to input terminals other than BNC connectors, make sure the polarity is correct in connection.
 - Do not demagnetize while the sensor of the current probe is clamping a conductor to be measured. Demagnetizing causes current to flow into the conductor, which may damage components of the circuit to be measured.
 - With the above considerations, as the demagnetized waveform will be generated when the current probe is energized, ensure that no conductor being measured is clamped to the current probe before providing power to the current probe.
3. Make sure the current sensor is locked and the opening lever should be in the locked position.
 4. Perform the demagnetization operation on the waveform measurement instrument or the Probe Display.
 5. Perform the zero adjustment operation on the waveform measurement instrument to adjust the trace to the zero position.

6.3 Measurement Procedure

1. Check and ensure that the system is safe and the preparations described in the preceding section have been ready.
2. Open the current sensor by pushing the opening lever in the arrow direction shown in the figure below, and the opening lever should be in the unlocked position.

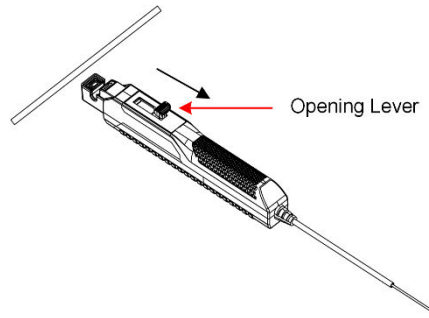

3. Adjust the current sensor to make its current direction indicator align with the actual current direction in the conductor. Clamp the sensor head around the conductor to be measured and put it in the center of the sensor head.
4. Lock the current sensor by pushing the opening lever in the arrow direction shown in the figure below, and the opening lever should be in the locked position.

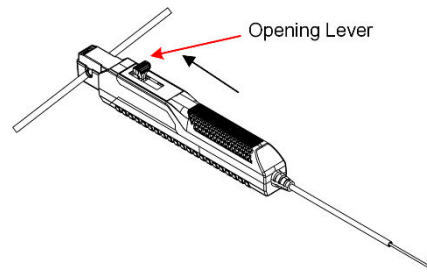

5. It is now possible to monitor the current waveform. You can adjust the scale to 0.1 V/A or 1 V/A on the Probe interface of the measurement instrument.

NOTE

The current consumption of the current probe depends on the current to be measured. The figure below shows the relation curve between the output current and current consumption.

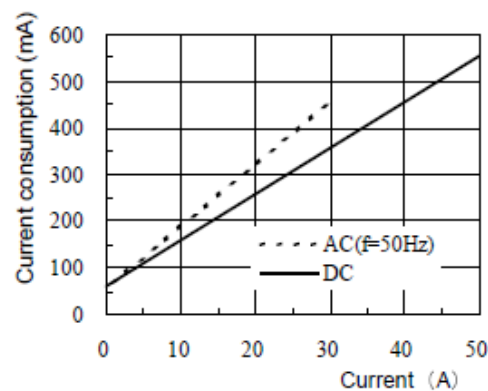

Figure 6.1 PCA3030

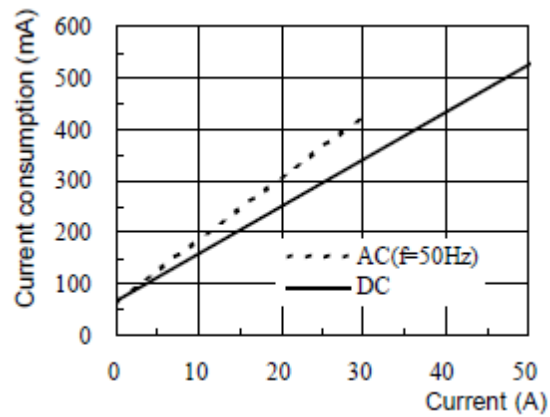

Figure 6.2 PCA3031

Note

The current consumption is the algebraic sum of the positive and negative current consumption.

6.4 Precautions for Measurement

CAUTION

1. The maximum continuous input range is based on the heat that is internally generated during the measurement. Never input current in excess of this level. Exceeding the rated level may result in damage to the probe.
2. The device may sustain damage from self-heating even at current levels that are lower than the maximum current value defined by the maximum rated current.

The maximum rated current is a recommended value that assumes sine-wave input under standard conditions. Self-heating may increase if the ambient temperature increases or the measurement current waveform contains other frequency components. Refer to *Appendix 2 Relation between Max Input Current and Frequency*.

3. If excess current is input, generated heat activates a built-in warning function that beeps indicating overload. If this happens, remove the input immediately (remove the sensor from the conductor being measured, or reduce the input current to zero). Wait until the sensor has had sufficient time to cool before resuming operation.

4. Heating generated during measurement of current with a frequency of 1 kHz or higher is mainly attributed to the self-heating of the sensor head. In this case, the built-in safety function will not be activated. Be careful to avoid accidents, such as a burn by heat, short-circuit, and damage to the sensor.
5. Even if the input current does not exceed the rated continuous maximum, continuous input for an extended period of time may activate the safety circuit to prevent damage resulting from heating of the sensor.
6. At a high ambient temperature, the built-in safety circuit may be activated even if the input current is below the rated continuous maximum.
7. Continuous input of current exceeding the rated maximum or repeated activation of the safety function may result in damage to the device.
8. The maximum input range is indicated by the Maximum Continuous Input Range. It is also indicated by another product specification Maximum Peak Current Value. Make sure that the input does not exceed the continuous maximum input range in rms.
9. Do not place any unclamped conductor with a current of a frequency of 10 kHz or higher near the sensor head, as shown in the following figure, as current flow in the conductor nearby may cause the temperature of the sensor head increase, leading to damage to the sensor.

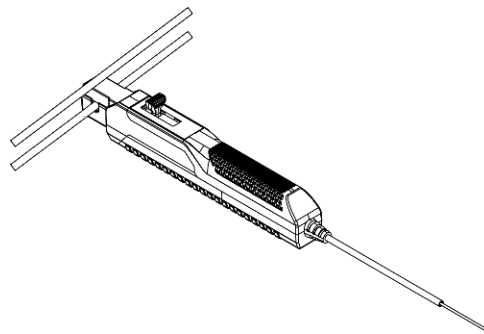

10. When opening the sensor head of the probe, be sure to operate with the opening lever. If an upper core is forced to open while the sensor head is locked, the open-close mechanism can be damaged.

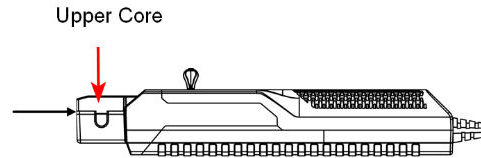
**NOTE**

1. Immediately after powering on, this device may be subject to an appreciable offset drift due to the effect of self-heating. To counteract this, allow the device to warm up for about 30 minutes before carrying out measurement.
2. When performing continuous measurements, it is necessary to be aware that the zero offset voltage will drift due to the impact of some factors such as the changes of the ambient temperature.
3. Under certain circumstances, oscillation may occur if the output connector is connected to the waveform measurement instrument that has been powered on. This does not indicate a malfunction. Oscillation can be stopped and operation restored to normal by opening and closing the clamp.
4. Depending on the amplitude and frequency of the current being measured, the sensor head may emit a resonant sound. This sound may also occur during demagnetizing operation, but it does not represent a malfunction (device failure).
5. If foreign matter becomes adhered to the gear mating surface of the sensor head, a slight gap will appear between its upper and lower layer. In this case, a resonant sound will be produced from the sensor head. Therefore, any foreign matter on the gear mating surface of the sensor head should be removed by using the cleaning method described in this manual.
6. An increase in the volume of the resonant sound during use may indicate that the gap between the upper and lower layer has increased. Since the sensor characteristics may change, it is recommended to calibrate the device.
7. Performing the demagnetization operation on the waveform measurement instrument will generate a demagnetized waveform. Although the waveform may

be asymmetrical with respect to the zero-volt line, it does not indicate a malfunction.

8. The reading may be affected by the position within the clamp aperture of the conductor being measured. The conductor should be in the center of the clamp aperture.
9. When carrying out measurement, make sure that the sensor head is locked, and the opening lever should be in the locked position. If the sensor head is not properly closed, accurate measurement will not be possible.
10. Accurate measurement may be impossible in locations subject to strong external magnetic fields, such as transformers and high current conductors, or in locations subject to strong external electric fields, such as radio transmission equipment.
11. At high frequencies, common mode noise may affect measurements taken on the high voltage side of the circuit. If this occurs, reduce the frequency range of the waveform measurement instrument or clamp onto the low-voltage side of the circuit, as appropriate.

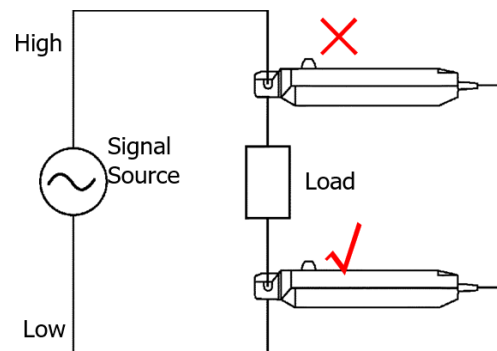

7 Specifications

When the device works for at least 30 minutes at $23^{\circ}\text{C}\pm 5^{\circ}\text{C}$, the following specifications can be guaranteed.

Table 7.1 PCA3000 Series

Model	PCA3030	PCA3031
Bandwidth	DC to 50 MHz (-3 dB)	DC to 120 MHz (-3 dB)
Rise Time	≤ 7 ns	≤ 2.92 ns
Maximum Continuous Current (2-second duration)	30 Arms (0.1V/A), 3 Arms (1V/A) , refer to <i>Appendix 2 Relation between Max Input Current and Frequency</i>	
Maximum Peak Current Value	Non-continuous 50A peak	
Current Transfer Ratio	0.1 V/A & 1 V/A	
Gain Accuracy	$\pm 1.0\%$ rdg ± 1 mV, ≤ 30 Arms $\pm 2.0\%$ rdg, 30-50A peak (DC, and 45 to 66 Hz, input within continuous maximum input range)	
Noise	≤ 2.0 mArms (for 20MHz band waveform measurement instrument)	
Resolution	1 mA	
Temperature Coefficient for Sensitivity	$\leq \pm 2\%$ (during input of 50 Hz, 30 Arms within the range of 0°C - 40°C)	
Maximum Rated Power	9 VA	
Operating Temperature and Humidity Range	0°C to 40°C , $\leq 80\%$ RH (no condensation)	

Model	PCA3030	PCA3031
Storage Temperature and Humidity Range	-10°C to 50°C, ≤80% RH (no condensation)	
Location for Use	Indoor, altitude up to 2,000 m, Pollution Degree 2	
Effect of External Magnetic Fields	≤20 mA (DC/50/60 Hz, Magnetic field of 400 A/m)	
Diameter of Conductor Available for Measurement	5 mm	
Delay	12 ns	
Probe Interface	RIGOL Probe 1.0	
Conductor Available for Measurement	Insulated conductor	
Guaranteed Accuracy Period	1 year (opening/closing up to 10,000 times)	
Cable Length	Sensor cable: approx. 1.2 m	
External Dimension	Sensor: approx. 175W×18H×40D (mm) (excluding protrusions) Terminator: approx. 27H×55W×18D (mm)	
Weight	268 g	
Accessories	Packing List, Probe Case	
Safety	EN61010	
EMC	EN61326	

8 Appendix

8.1 Appendix 1 Amplitude-Frequency Characteristics

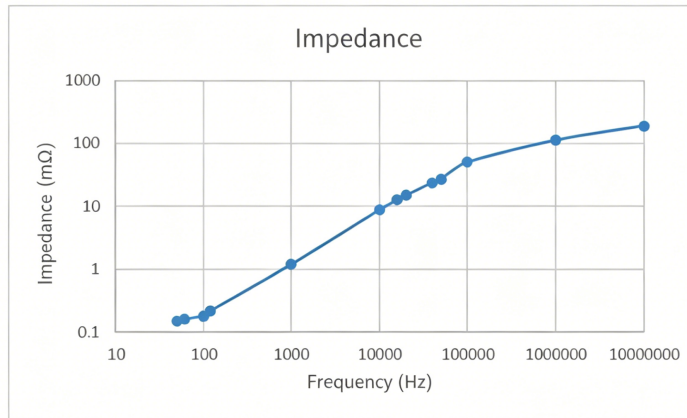

8.2 Appendix 2 Relation between Max Input Current and Frequency

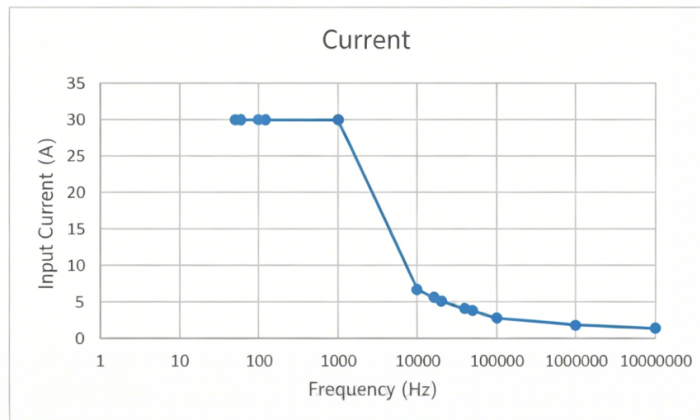

9 Care and Cleaning

Care

Do not leave the probe and its accessories where it may be exposed to sunlight for long periods of time.



CAUTION

Do not expose the probe and its accessories to caustic liquids.

Cleaning

Clean the probe and its accessories according to the operating conditions.

1. Disconnect the probe from the oscilloscope or the power source.
2. Wipe the exterior surfaces of the probe and its accessories with a soft cloth dampened with a mild detergent or water solution.



WARNING

To avoid short circuits or personal injury caused by moisture, make sure that the probe is completely dry before use.

10 Warranty

RIGOL TECHNOLOGIES CO., LTD. (hereinafter referred to as RIGOL) warrants that the product mainframe and product accessories will be free from defects in materials and workmanship within the warranty period. If a product proves defective within the warranty period, RIGOL guarantees free replacement or repair for the defective product.

To get repair service, please contact your nearest RIGOL sales or service office.

There is no other warranty, expressed or implied, except such as is expressly set forth herein or other applicable warranty card. There is no implied warranty of merchantability or fitness for a particular purpose. Under no circumstances shall RIGOL be liable for any consequential, indirect, ensuing, or special damages for any breach of warranty in any case.

Boost Smart World and Technology Innovation

Industrial Intelligent
Manufacturing



Semiconductors

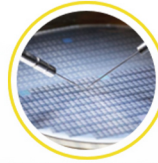

Education &
Research

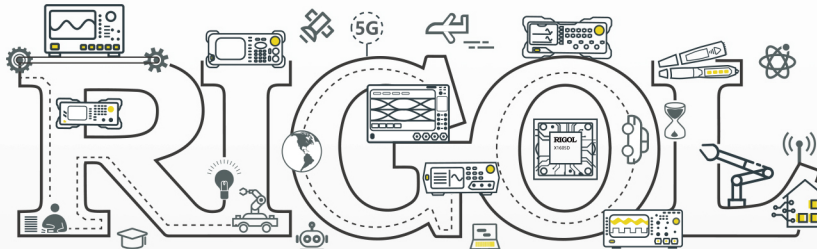

Communication

System Integration

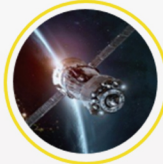

New Energy



- 5G Cellular-5G/WIFI
- UWB/RFID/ ZIGBEE
- Digital Bus/Ethernet
- Optical Communication

- Digital/Analog/RF Chip
- Memory and MCU Chip
- Third-Generation Semiconductor
- Solar Photovoltaic Cells

- New Energy Automobile
- PV/Inverter
- Power Test
- Automotive Electronics

*Provide Testing and Measuring Products
and Solutions for Industry Customers*

HEADQUARTER

RIGOL TECHNOLOGIES CO., LTD.
No.8 Keling Road, New District,
Suzhou, JiangSu, P.R.China
Tel: +86-400620002
Email: info-cn@rigol.com

JAPAN

RIGOL JAPAN CO., LTD.
5F, 3-45-6, Minamiotsuka, Toshima-Ku,
Tokyo, 170-0005, Japan
Tel: +81-3-6262-8932
Fax: +81-3-6262-8933
Email: info.jp@rigol.com

EUROPE

RIGOL TECHNOLOGIES EU GmbH
Friedrichshafener Str. 5
82205 Gilching
Germany
Tel: +49(0)8105-27292-21
Email: info-europe@rigol.com

KOREA

RIGOL KOREA CO., LTD.
5F, 222, Gonghang-daero,
Gangseo-gu, Seoul, Republic of Korea
Tel: +82-2-6953-4466
Fax: +82-2-6953-4422
Email: info.kr@rigol.com

NORTH AMERICA

RIGOL TECHNOLOGIES, USA INC.
10220 SW Nimbus Ave.
Suite K-7
Portland, OR 97223
Tel: +1-877-4-RIGOL-1
Email: sales@rigol.com

For Assistance in Other Countries

Email: info.int@rigol.com