



**RIGOL**

# VSA Mode

---

For RSA6000 Series  
Spectrum Analyzer

User Guide

Jan.2026

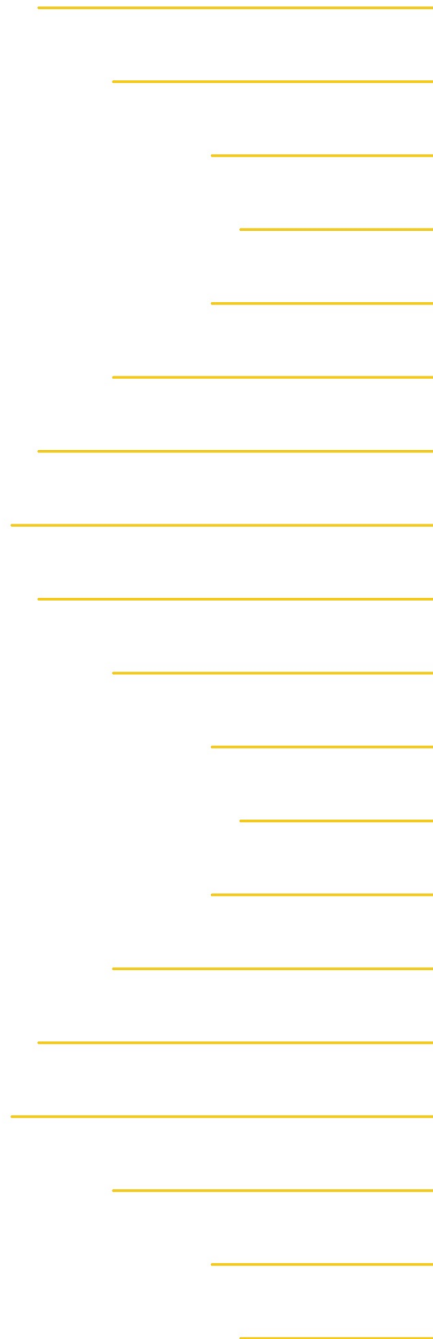

## **Guaranty and Declaration**

### **Copyright**

© 2025 RIGOL TECHNOLOGIES CO., LTD. All Rights Reserved.

### **Trademark Information**

RIGOL® is the trademark of RIGOL TECHNOLOGIES CO., LTD.

### **Notices**

- RIGOL products are covered by P.R.C. and foreign patents, issued and pending.
- RIGOL reserves the right to modify or change parts of or all the specifications and pricing policies at the company's sole decision.
- Information in this publication replaces all previously released materials.
- Information in this publication is subject to change without notice.
- RIGOL shall not be liable for either incidental or consequential losses in connection with the furnishing, use, or performance of this manual, as well as any information contained.
- Any part of this document is forbidden to be copied, photocopied, or rearranged without prior written approval of RIGOL.

### **Product Certification**

RIGOL guarantees that this product conforms to the national and industrial standards in China as well as the ISO9001:2015 standard and the ISO14001:2015 standard. Other international standard conformance certifications are in progress.

### **Contact Us**

If you have any problem or requirement when using our products or this manual, please contact RIGOL.

E-mail: [service@rigol.com](mailto:service@rigol.com)

Website: <http://www.rigol.com>

Section	Description	Page
	List of Figures.....	V
	List of Tables.....	VI
1	Safety Requirement .....	1
1.1	General Safety Summary .....	1
1.2	Safety Notices and Symbols .....	2
1.3	Measurement Category .....	3
1.4	Ventilation Requirement .....	4
1.5	Working Environment .....	4
1.6	Care and Cleaning .....	6
1.7	Environmental Considerations .....	6
2	RSA6000 Series Spectrum Analyzer .....	7
3	Document Overview .....	8
4	Quick Start .....	10
4.1	User Interface .....	10
4.2	Mode Setting .....	11
4.3	To View the Option and the Option Installation .....	12
5	Front Panel Function Keys .....	14
5.1	Basic Settings .....	14
5.1.1	FREQ .....	14
5.1.1.1	Center Frequency .....	14
5.1.1.2	CF Step .....	14
5.1.1.3	CF Step Mode .....	15
5.1.2	Display .....	15
5.1.2.1	Display View .....	15
5.1.2.2	Parameter Setting .....	17
5.1.3	AMPT .....	20
5.1.3.1	Range .....	20
5.1.3.2	Auto Scale .....	20
5.1.3.3	Ref Value .....	21
5.1.3.4	Scale/Div .....	22
5.1.3.5	Reference Pos .....	22
5.1.3.6	Y Axis Unit .....	23
5.1.3.7	Last Scale .....	23

5.1.3.8 Copy Y Scale .....	23
5.2 Sweep and Function Settings .....	23
5.2.1 BW .....	23
5.2.1.1 FFT Window .....	23
5.2.2 Sweep .....	24
5.2.2.1 Sweep Settings .....	25
5.2.3 Trigger .....	25
5.2.3.1 Trigger Source .....	25
5.2.3.2 Free Run .....	25
5.2.3.3 External Trigger .....	25
5.2.3.4 IF Power Trigger .....	26
5.2.3.5 Trigger Holdoff State .....	27
5.2.3.6 Trigger Holdoff .....	27
5.2.3.7 Auto Trig State .....	27
5.2.3.8 Auto Trig .....	28
5.3 Measurement Settings .....	28
5.3.1 Meas Setup .....	28
5.3.1.1 Setting .....	29
5.3.1.2 Burst/Sync Search .....	31
5.3.1.3 BER .....	33
5.3.1.4 Pre-demod .....	35
5.3.1.5 Global CF Mode .....	35
5.4 Marker .....	36
5.4.1 Marker Setting .....	36
5.4.1.1 Selected Marker .....	36
5.4.1.2 Next Marker .....	36
5.4.1.3 Marker Mode .....	37
5.4.1.4 Reference Marker .....	38
5.4.1.5 Marker Trace .....	38
5.4.1.6 Marker X .....	38
5.4.1.7 Marker Y .....	38
5.4.1.8 Marker Y Image .....	39
5.4.1.9 Couple Markers .....	39
5.4.1.10 All Markers Off .....	39
5.4.2 Marker To .....	39
5.4.2.1 Mkr->CF .....	39
5.4.2.2 Mkr->Step .....	40

5.4.2.3	Mkr->Ref	40
5.4.2.4	Marker $\Delta$ ->CF	40
5.4.3	Marker Function	40
5.4.3.1	Band Function	40
5.4.3.2	Band Setting	41
5.4.4	Peak Search	41
5.4.4.1	Peak Search	41
5.4.4.2	Next Peak	41
5.4.4.3	Next Higher	42
5.4.4.4	Next Peak Right	42
5.4.4.5	Next Peak Left	42
5.4.4.6	Minimum Search	42
5.4.4.7	Continuous Peak	42
5.5	Input/Output	42
5.5.1	Input Impedance	42
5.5.2	Ext Gain	42
5.5.3	Trig Out	43
5.6	Shortcut Key	43
5.6.1	Preset	43
5.6.2	Single/Continue	47
5.6.3	Restart	47
5.7	System Utility Function Setting	47
5.7.1	System	47
5.7.1.1	I/O Setting	47
5.7.1.2	Basic Settings	50
5.7.1.3	About this Spectrum	51
5.7.1.4	Options	52
5.7.1.5	Calibration	52
5.7.2	File	52
5.7.2.1	File Management	52
5.7.2.2	New Folder	53
5.7.2.3	Rename	53
5.7.2.4	Cut	53
5.7.2.5	Copy	53
5.7.2.6	Paste	53
5.7.2.7	Delete	53
5.7.2.8	Security Clear	54

---

5.7.3	Recall	54
5.7.3.1	State	54
5.7.3.2	Measurement Data	54
5.7.4	Save	54
5.7.4.1	State	55
5.7.4.2	Preset	55
5.7.4.3	Measurement Data	55
5.7.4.4	Screen Image	56
5.7.5	Update	56
5.7.6	Help Menu	56
5.7.7	Shutdown	56
5.7.8	Restart	57
6	Remote Control	58
6.1	Remote Control via USB	58
6.2	Remote Control via LAN	59
7	Appendix	61
7.1	Appendix A: Options and Accessories	61
7.2	Appendix B: Warranty	62

# List of Figures

Figure 4.1 User Interface .....	10
Figure 5.1 Measurement Setting Interface .....	17
Figure 5.2 Relationship of Trigger Parameters .....	28
Figure 5.3 Relationship of Burst Search Parameters .....	31
Figure 5.4 Sync Pattern .....	33

## List of Tables

Table 5.3 Reference Value (Time-Domain Data) .....	18
Table 5.4 Reference Value (Frequency-Domain Data) .....	18
Table 5.5 Width (Time-Domain Data) .....	19
Table 5.6 Width (Frequency-Domain Data) .....	19

# 1 Safety Requirement

---

## 1.1 General Safety Summary

---

Please review the following safety precautions carefully before putting the instrument into operation so as to avoid any personal injury or damage to the instrument and any product connected to it. To prevent potential hazards, please follow the instructions specified in this manual to use the instrument properly.

- **Use Proper Power Cord.**

Only the exclusive power cord designed for the instrument and authorized for use within the local country could be used.

- **Ground the Instrument.**

The instrument is grounded through the Protective Earth lead of the power cord. To avoid electric shock, it is essential to connect the earth terminal of the power cord to the Protective Earth terminal before connecting any inputs or outputs.

- **Observe All Terminal Ratings.**

To avoid fire or shock hazard, observe all ratings and markers on the instrument and check your manual for more information about ratings before connecting the instrument.

- **Use Proper Overvoltage Protection.**

Ensure that no overvoltage (such as that caused by a bolt of lightning) can reach the product. Otherwise, the operator might be exposed to the danger of an electric shock.

- **Do Not Operate Without Covers.**

Do not operate the instrument with covers or panels removed.

- **Do Not Insert Objects Into the Air Outlet.**

Do not insert anything into the holes of the fan to avoid damaging the instrument.

- **Use Proper Fuse.**

Please use the specified fuses.

- **Avoid Circuit or Wire Exposure.**

Do not touch exposed junctions and components when the unit is powered on.

- **Do Not Operate With Suspected Failures.**

If you suspect damage occurs to the instrument, have it inspected by RIGOL authorized personnel before further operations. Any maintenance, adjustment or

replacement especially to circuits or accessories must be performed by RIGOL authorized personnel.

- **Provide Adequate Ventilation.**

Inadequate ventilation may cause an increase of temperature in the instrument, which would cause damage to the instrument. So please keep the instrument well ventilated and inspect the air outlet and the fan regularly.

- **Do Not Operate in Wet Conditions.**

To avoid short circuit inside the instrument or electric shock, never operate the instrument in a humid environment.

- **Do Not Operate in an Explosive Atmosphere.**

To avoid personal injuries or damage to the instrument, never operate the instrument in an explosive atmosphere.

- **Keep Instrument Surfaces Clean and Dry.**

To avoid dust or moisture from affecting the performance of the instrument, keep the surfaces of the instrument clean and dry.

- **Prevent Electrostatic Impact.**

Operate the instrument in an electrostatic discharge protective environment to avoid damage induced by static discharges. Always ground both the internal and external conductors of cables to release static before making connections.

- **Use the Battery Properly.**

Do not expose the battery (if available) to high temperature or fire. Keep it out of the reach of children. Improper change of a battery (lithium battery) may cause an explosion. Use the RIGOL specified battery only.

- **Handle with Caution.**

Please handle with care during transportation to avoid damage to keys, knobs, interfaces, and other parts on the panels.



**WARNING**

Equipment meeting Class A requirements may not offer adequate protection to broadcast services within residential environment.

## 1.2 Safety Notices and Symbols

Safety Notices in this Manual:



**WARNING**

Indicates a potentially hazardous situation or practice which, if not avoided, will result in serious injury or death.



### CAUTION

Indicates a potentially hazardous situation or practice which, if not avoided, could result in damage to the product or loss of important data.

#### Safety Notices on the Product:

- **DANGER**  
It calls attention to an operation, if not correctly performed, could result in injury or hazard immediately.
- **WARNING**  
It calls attention to an operation, if not correctly performed, could result in potential injury or hazard.
- **CAUTION**  
It calls attention to an operation, if not correctly performed, could result in damage to the product or other devices connected to the product.

#### Safety Symbols on the Product:



Hazardous  
Voltage



Safety Warning



Protective Earth  
Terminal

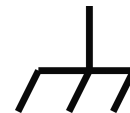

Chassis Ground



Test Ground

## 1.3 Measurement Category

### Measurement Category

This instrument can make measurements in Measurement Category I.



### WARNING

This instrument can only be used for measurements within its specified measurement categories.

#### Measurement Category Definitions

- **Measurement category I** is for measurements performed on circuits not directly connected to MAINS. Examples are measurements on circuits not derived from MAINS, and specially protected (internal) MAINS derived circuits. In the latter case, transient stresses are variable. Thus, you must know the transient withstand capability of the equipment.
- **Measurement category II** is for measurements performed on circuits directly connected to low voltage installation. Examples are measurements on household appliances, portable tools and similar equipment.

- **Measurement category III** is for measurements performed in the building installation. Examples are measurements on distribution boards, circuit-breakers, wiring (including cables, bus-bars, junction boxes, switches and socket-outlets) in the fixed installation, and equipment for industrial use and some other equipment. For example, stationary motors with permanent connection to a fixed installation.
- **Measurement category IV** is for measurements performed at the source of a low-voltage installation. Examples are electricity meters and measurements on primary overcurrent protection devices and ripple control units.

## 1.4 Ventilation Requirement

This instrument uses a fan to force cooling. Please make sure that the air inlet and outlet areas are free from obstructions and have free air. When using the instrument in a bench-top or rack setting, provide at least 10 cm clearance beside, above and behind the instrument for adequate ventilation.



### CAUTION

Inadequate ventilation may cause an increase of temperature in the instrument, which would cause damage to the instrument. So please keep the instrument well ventilated and inspect the air outlet and the fan regularly.

## 1.5 Working Environment

### Temperature

Operating: 0°C to +50°C

Non-operating: -20°C to +70°C

### Humidity

- **Operating:**
  - Below +30°C: ≤95% RH (without condensation)
  - +30°C to +40°C: ≤75% RH (without condensation)
  - +40°C to +50°C: ≤45% RH (without condensation)
- **Non-operating:**
  - Below +40°C: 5%~ 90% (without condensation)
  - ≥+40°C to <+60°C: 5%~ 80% (without condensation)
  - >+60°C to <+70°C: 5%~ 40% (without condensation)

**WARNING**

To avoid short circuit inside the instrument or electric shock, never operate the instrument in a humid environment.

**Altitude**

**Operating:** below 3 km

**Protection Level Against Electric Shock**

- **Contact discharge:**±4 kV
- **Air discharge:**±8 kV

**Installation (Overvoltage) Category**

This product is powered by mains conforming to installation (overvoltage) category II.

**WARNING**

Ensure that no overvoltage (such as that caused by a bolt of lightning) can reach the product. Otherwise, the operator might be exposed to the danger of an electric shock.

**Installation (Overvoltage) Category Definitions**

Installation (overvoltage) category I refers to signal level which is applicable to equipment measurement terminals connected to the source circuit. Among these terminals, precautions are done to limit the transient voltage to a low level.

Installation (overvoltage) category II refers to the local power distribution level which is applicable to equipment connected to the AC line (AC power).

**Pollution Degree**

Pollution Degree 2

**Pollution Degree Definition**

- **Pollution Degree 1:** No pollution or only dry, nonconductive pollution occurs. The pollution has no effect. For example, a clean room or air-conditioned office environment.
- **Pollution Degree 2:** Normally only nonconductive pollution occurs. Temporary conductivity caused by condensation is to be expected. For example, indoor environment.
- **Pollution Degree 3:** Conductive pollution or dry nonconductive pollution that becomes conductive due to condensation occurs. For example, sheltered outdoor environment.
- **Pollution Degree 4:** The pollution generates persistent conductivity caused by conductive dust, rain, or snow. For example, outdoor areas.

### Safety Class

Class 1 – Grounded Product

## 1.6 Care and Cleaning

### Care

Do not store or leave the instrument where it may be exposed to direct sunlight for long periods of time.

### Cleaning

Clean the instrument regularly according to its operating conditions.

1. Disconnect the instrument from all power sources.
2. Clean the external surfaces of the instrument with a soft cloth dampened with mild detergent or water. Avoid having any water or other objects into the chassis via the heat dissipation hole. When cleaning the LCD, take care to avoid scarifying it.

### CAUTION

To avoid damage to the instrument, do not expose it to caustic liquids.



### WARNING

To avoid short-circuit resulting from moisture or personal injuries, ensure that the instrument is completely dry before connecting it to the power supply.



## 1.7 Environmental Considerations

The following symbol indicates that this product complies with the WEEE Directive 2012/19/EU.



The equipment may contain substances that could be harmful to the environment or human health. To avoid the release of such substances into the environment and avoid harm to human health, we recommend you to recycle this product appropriately to ensure that most materials are reused or recycled properly. Please contact your local authorities for disposal or recycling information.

You can click on the following link <https://www.rigol.com/intl/services/environmental-protection-statement.html> to download the latest version of the RoHS&WEEE certification file.

## 2 **RSA6000 Series Spectrum Analyzer**

---

RSA6000 series is RIGOL's newly launched real-time spectrum analyzer. Its excellent performance in SFDR, phase noise, amplitude accuracy and test speed makes it applicable in various test scenarios such as spectrum analysis, real-time spectrum analysis, vector signal analysis, pulse analysis. RSA6000 series real-time spectrum analyzer has a strong expansion capability, allowing you to build the test system or perform user-defined development via various digital and analog output interfaces. With its excellent performance and flexible configuration, it can meet your test demands in various application scenarios such as wireless communication, automobile electronics, Internet of Things (IoT), and etc.

## 3 Document Overview

This manual gives you a quick review about the front and rear panel of RSA6000 series, the user interface, and its basic operation method.



### TIP

For the latest version of this manual, download it from the official website of RIGOL (<http://www.rigol.com>).

### Publication Number

UGD28102-1110

### Software Version

00.00.11

Software upgrade might change or add product features. Please acquire the latest version of the manual from RIGOL website or contact RIGOL to upgrade the software.

### Format Conventions in this Manual

#### 1. Key

The front panel key is denoted by the menu key icon. For example,  indicates the "System" key.

#### 2. Menu

The menu item is denoted by the format of "Menu Name (Bold) + Character Shading" in the manual. For example, **Setup** indicates clicking or tapping the "Setup" sub-menu under the system menu to view the basic setting configuration items.

#### 3. Operation Procedures

The next step of the operation is denoted by ">" in the manual. For example, 

> **Save** indicates that first clicking or tapping the icon , then clicking or tapping **Save**.

#### 4. Connector

The connectors on the front or rear panel are usually denoted by the format of "Connector Name (Bold) + Square Brackets (Bold)". For example, **[Gen Output 50Ω]**.

## Content Conventions in this Manual

The RSA6000 series spectrum analyzer includes the following models. Unless otherwise specified, this manual takes RSA6265 as an example to illustrate the functions and operation methods of the RSA6000 series.

Model	Frequency Range
RSA6265	5 kHz to 26.5 GHz
RSA6140	5 kHz to 14 GHz
RSA6085	5 kHz to 8.5 GHz

# 4 Quick Start

This chapter gives you a quick review about the user interface of the RSA6000 series spectrum analyzer in VSA mode and its mode settings. For its details about the appearance and dimensions, its front and rear panel, as well as notices during first use of the analyzer, refer to relevant chapters in *RSA6000 User Guide*.

## 4.1 User Interface

The user interface of VSA mode is shown in the following figure.

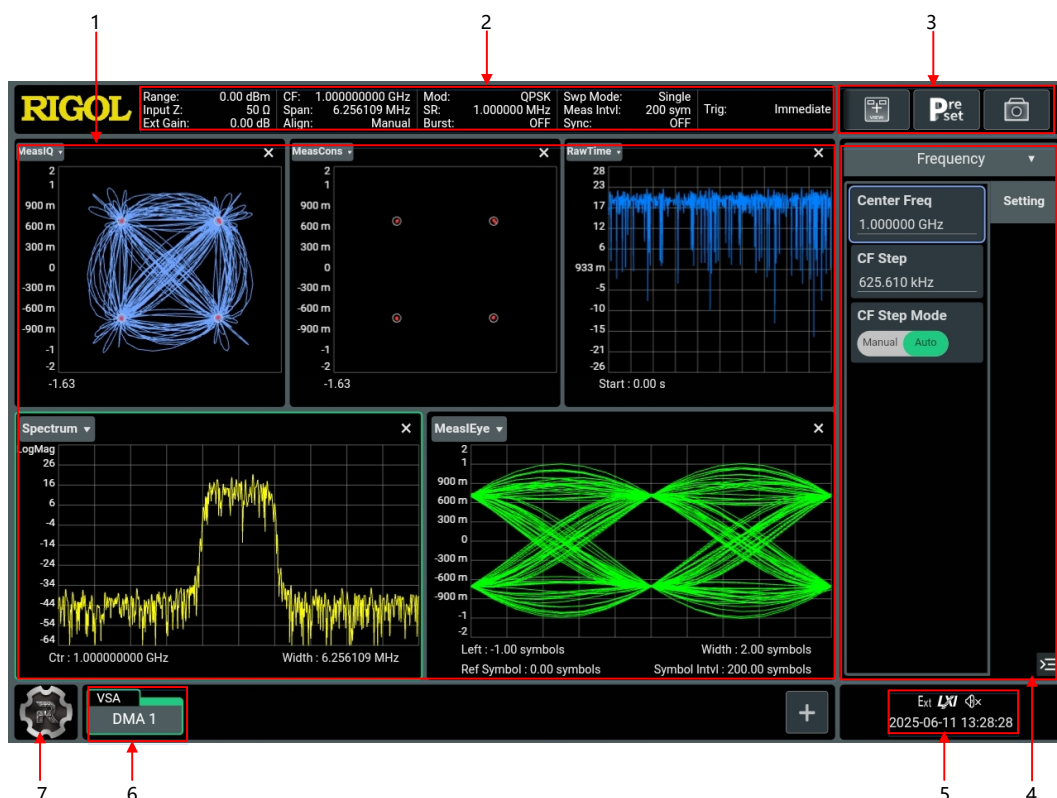





Figure 4.1 User Interface

No.	Name	Description
1	Multi-pane Windowing Display Area	If you enable multiple functions, multiple windows can be displayed on the screen at one time.
2	Status Display Bar	Displays the frequency, amplitude, span, trigger, and other measurement parameters.
3	Quick Operation Menu	Displays the quick operation menu.

No.	Name	Description
4	Menu Control Operation	Sets the main measurement types Meas Setup, Frequency, Sweep, Amplitude, BandWidth, Marker, etc.
5	Notification Area	Displays the USB storage device icon, LAN connection icon, sound icon, remote control icon, and system time. You can click or tap this area to enter the system menu.
6	Working Mode	Displays the currently selected working mode. The analyzer provides five modes: GPSA, RTSA, VSA, EMI, and ADM.
7	Function Navigation Icon	Click or tap the icon  to open the function navigation menu. Click or tap the specified menu icon to enter the specified function setting menu.

## 4.2 Mode Setting

RSA6000 provides five measurement modes: GPSA, RTSA, ADM (option), EMI (option), and VSA (option). Press the front-panel key  to enter the measurement setting menu. You can also click or tap  to select the desired measurement mode.

### 1. GPSA

GPSA adopts two analysis methods: swept SA and FFT. It can not only carry out frequency domain analysis, but also time domain (zero span) analysis.

Select GPSA. In this working mode, you can click or tap to select the desired measurement. For details, refer to relevant chapters in *RSA6000 User Guide*.

### 2. RTSA

RTSA provides the real-time signal analysis function, enabling you to capture the complex signal seamlessly.

Select RTSA. In this working mode, you can click or tap **Meas Setup** or other measurement items to set the measurement parameters. For details, refer to relevant chapters in *RSA6000 User Guide*.

### 3. VSA

VSA mode provides the standard vector signal analysis function. If you need this function, please purchase this option (order No. RSA6000-VSA), and install it according to instructions in "*To View the Option and the Option Installation*".

### 4. EMI

EMI mode provides the EMI pre-compliance measurement function. If you need this function, please purchase this option (order No. RSA6000-EMI), and install it according to instructions in "[To View the Option and the Option Installation](#)".

## 5. ADM

ADM mode provides the analog signal demodulation function. In the measurement setting interface, you can click or tap **ADM** and then select AM, FM, or PM. If you need this function, please purchase this option (order No. RSA6000-ADM), and install it according to instructions in "[To View the Option and the Option Installation](#)".

## 4.3 To View the Option and the Option Installation

This series spectrum analyzer provides many options to meet various measurement requirements. If you need any of these options, order them according to the Order No. available in "[Appendix A: Options and Accessories](#)", and then install the options according to this section. Besides, you can also view the options currently installed on the spectrum analyzer and activate the newly purchased option.

### 1. View the Installed Option

If your instrument has currently installed the option, perform the following operations to view the name of the installed option and other detailed information about the option from the option list.

- Click or tap the function navigation icon  at the lower-left corner of the screen, and then select **System** to enter the system setting menu.
- Click or tap **Options** to view the options currently installed.

### 2. Install the Option

The option license is a string with a fixed number of characters. Each instrument has one unique license. The license file should be in specific format, with the filename extension "\*.lic". After you purchase an option, you will obtain a key (used for obtaining the license). Then, you can install the option according to the following steps.

#### a. Obtain an option license

- a. Log in to the **RIGOL** official website (<http://www.rigol.com>), click **SERVICE CENTRE > License Activation** to enter the license activation interface.
- b. Input the correct key, serial number (To obtain the serial number, click or tap the function navigation icon  at the lower-left corner of the screen first, then click or tap **System**. Click or tap **About** to acquire the serial number of the instrument.), and verification code. Click **Generate** to acquire the download link for the option license file. If you need to use the option

license file, please click the link to download the file to the root directory of the USB storage device.

**b. Install the option**

- a. Install the option by sending SCPI commands. For details, refer to *VSA Programming Guide*.
- b. After installation, a prompt message "Option activated successfully" is displayed. After the option has been installed, you are recommended to restart the instrument.



**TIP**

- During the installation process, you are not allowed to power off the instrument.
- To install the option, send the relevant SCPI command. Installing options by inputting the license code manually is not supported.

## 5 Front Panel Function Keys

This chapter describes in detail the front-panel function keys and their sub-menu functions of RSA6000 series spectrum analyzer in the VSA mode.

### 5.1 Basic Settings

#### 5.1.1 FREQ

Sets the frequency parameters of the analyzer.

##### 5.1.1.1 Center Frequency

**Sets the center frequency of the current channel.**

Key Points:

- Modifying the center frequency indicates that the frequency is changed along the current channel horizontally, and the adjustable range should be within the frequency range specified in the technical specifications of the analyzer.
- You can use the numeric keys, the knob, or arrow keys to modify this parameter; you can also use the touch screen to modify the parameter.

Parameter	Remarks
Default	1 GHz
Range	1.564 kHz to (Fmax <sup>[1]</sup> -1.564 kHz
Unit	GHz, MHz, kHz, Hz
Knob Step	step = span/200, Min = 1 Hz
Left/Right Arrow Key Step	CF step



#### NOTE

[1]: The maximum measurement frequency Fmax is determined by the instrument model.

##### 5.1.1.2 CF Step

Changes the step size for the center frequency. Changing the center frequency by a constant step-size value switches the channel to be measured continuously.

Remarks:

- Set a proper CF step value, and then select the center frequency. Use the Left/Right arrow key to switch the measurement channel at a fixed step size. Thus, the instrument can sweep the adjacent channels manually.
- You can use the numeric keys, the knob, or arrow keys to modify this parameter; you can also use the touch screen to modify the parameter.

Parameter	Remarks
Default	span/10
Range	-Fmax to Fmax
Unit	GHz, MHz, kHz, Hz
Knob Step	step = span/200, Min = 1 Hz
Left/Right Arrow Key Step	at 1-2-5 step

### 5.1.1.3 CF Step Mode

The CF step mode consists of "Manual" and "Auto".

Remarks:

- In Auto mode, the CF step is 1/10 of the span.
- In Manual mode, you can use the numeric keys to set the step size.

## 5.1.2 Display

### 5.1.2.1 Display View

#### Select the Display View



Click or tap  on the quick operation tool bar at the upper-right part of the screen to select the desired display view. You can also click or tap the drop-down button of the display view name to set the display view for the selected trace.

#### 1. Capture Data

Sets the displayed pre-demodulation data of the selected trace to "RawTime" or "Spectrum".

#### 2. Meas Signal

Selects the time domain or frequency domain demodulation data of the selected trace.

- The time-domain data include "MeasLog", "MeasLin", "MeasReal", "MeasImag", "MeasPhase", "MeasPhaseUnwrap", "MeasIQ", "MeasCons", "MeasEye", and "MeasQEye".
- The frequency-domain data include "MeasSpectrum".

### 3. Ref Signal

Sets the displayed reference signal data of the selected trace to time-domain or frequency-domain data.

- The time-domain data include "RefLog", "RefLin", "RefReal", "RefImag", "RefPhase", "RefPhaseUnwrap", "RefIQ", "RefCons", "RefEye", and "RefQEye".
- The frequency-domain data include "RefSpectrum".

### 4. Demod Error

Selects the demodulation error data of the selected trace.

#### a. EVMErrorTime

Displays the vector difference between the IQ measurement time and IQ reference time at each time point.

#### b. EVMErrorSpectrum

Displays the FFT operation results of the vector difference between the IQ measurement time and IQ reference time at each time point.

#### c. MagError

Displays the amplitude difference between the IQ measurement signal and the reference signal at each time point.

#### d. PhaseError

Displays the phase difference between the IQ measurement signal and the reference signal at each time point.

### 5. Demod Bits

Selects the view, and user interface displays the restored symbol after the digital demodulation. At this time, the spectrum selects the symbol as the trace data.

### 6. Meas

Click or tap this menu to display the error summary in the display view. If you select a different demodulation type, the displayed error results are different.

**Combination View**

Click or tap **Display** > **Display View** > **Comb View** to select the displayed view type. The available views include "Normal", "Demod Trace", "Demod Error", and "Result Summary".



You can also click or tap  at the bottom of the screen to open the measurement setting interface and select the desired view.

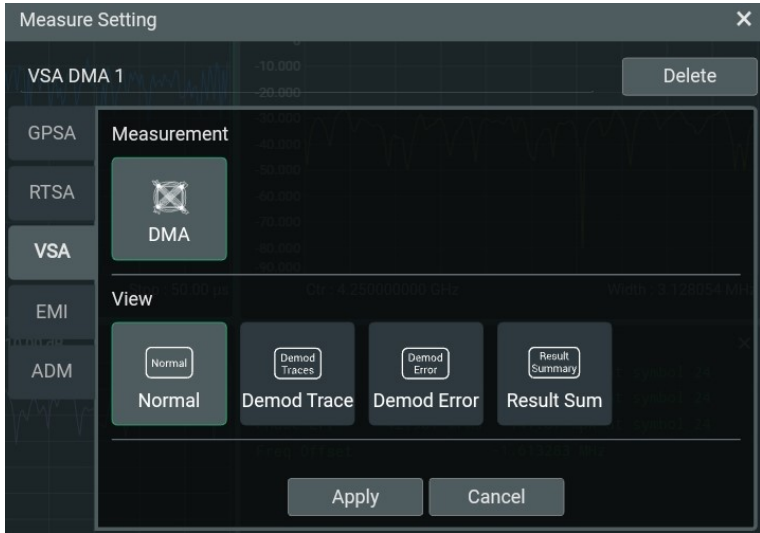

**Figure 5.1 Measurement Setting Interface**

**Restore View**

Restores the layout of the current combination view to its defaults. If the layout remains unchanged, and you have modified the display view type, click or tap this menu to restore to its previously selected display view.



**TIP**

If you have modified the default layout of the current combination view, click or tap **Restore View**, the modified layout may be lost and will not saved to the state file.

**5.1.2.2 Parameter Setting**

**X Scale**

When "X Scale" is enabled, the reference value and width are automatically adjusted based on the measurement settings. At this time, Ref Value and Width menus are disabled and grayed out. You cannot modify it manually. When "X Scale" is disabled, you can adjust the reference value and width manually.

### Ref Value

Sets the X-axis reference value of the selected trace. When the time-domain data source is selected, the reference unit is symbol or s; when the frequency-domain data source is selected, the reference unit is Hz.

**Table 5.3 Reference Value (Time-Domain Data)**

Parameter	Remarks
Default	0 (0 $\mu$ s)
Range	(-1e+12) to (1e+12)
Unit	Symbol (s, ms, $\mu$ s, ns, ps)
Knob Step	Width/100
Left/Right Arrow Key Step	Width/10

**Table 5.4 Reference Value (Frequency-Domain Data)**

Parameter	Remarks
Default	998.4375 MHz
Range	-1 THz to 1 THz
Unit	GHz, MHz, kHz, Hz
Knob Step	Width/100
Left/Right Arrow Key Step	Width/10

### Width

Sets the X-axis width of the selected trace. When the time-domain data source is selected, the reference unit is symbol or s; when the frequency-domain data source is selected, the reference unit is Hz.

Key Points:

- For the frequency-domain trace, the X-axis width can be set to be smaller than the span, enabling you to zoom in on a portion of the measurement values.
- For the time-domain trace, the X-axis width can be set to be smaller than the time span, enabling you to zoom in on a portion of the measurement values.

**Table 5.5 Width (Time-Domain Data)**

Parameter	Remarks
Default	50 $\mu$ s
Range	0 to (1e+12)
Unit	Symbol (s, ms, us, ns, ps)
Knob Step	Width/100
Left/Right Arrow Key Step	Width/10

**Table 5.6 Width (Frequency-Domain Data)**

Parameter	Remarks
Default	3.128055 MHz
Range	1 THz to 1 THz
Unit	GHz, MHz, kHz, Hz
Knob Step	Width/100
Left/Right Arrow Key Step	Width/10

**Ref Position**

Sets X-axis scale's reference value of the selected trace. It can be set to "Left", "Center", and "Right".

**Last Scale**

Sets X Scale to the last modified X-axis reference value and X-axis width. When X Scale is enabled, this menu item is grayed out and disabled.

**Copy X Scale**

Copies the X scale setting of the currently selected view to all other views that have the same X-axis dimension. The available view types include "Capture Data", "Meas Signal", "Ref Signal", and "Demod Error". For detailed view selection, refer to *Select the Display View*.

## Eye Length

Click or tap **Eye Length** to set the eye length. It is expressed in symbol.

### NOTE

This menu is enabled when the trace is displayed in eye view.

Parameter	Remarks
Default	2
Range	1 to 40
Unit	None
Knob Step	1
Left/Right Arrow Key Step	1

## 5.1.3 AMPT

Sets the amplitude parameters of the analyzer. You can modify these parameters to make the signals under test be displayed with minimal errors in the current window, easy for you to observe.

### 5.1.3.1 Range

Sets the amplitude of the largest sinusoidal input signal without being clipped by the IF ADC.

Parameter	Remarks
Default	20 dBm
Range	-15 dBm to +25 dBm
Unit	dBm
Knob Step	1 dBm
Left/Right Arrow Key Step	10 dBm

### 5.1.3.2 Auto Scale

Sets the Y-axis reference value and the Y-axis scale value automatically to ensure that the signal can be fully displayed for better observation of the trace.

## 5.1.3.3 Ref Value

Sets the Y-axis reference value of the selected trace.

Parameter	Remarks
Default	0
Range	(-1e+12) to (1e+12)
Unit	Refer to " <i>Y-axis Ref Value</i> ".
Knob Step	(Scale/Div)/10
Left/Right Arrow Key Step	Scale/Div

Display View Type	Y Axis Unit Type	Ref Value	Scale/Div
Raw Time	Peak	dBV <sub>pk</sub>	dB
	RMS	dBV <sub>rms</sub>	dB
	Power	dBm	dB
Spectrum	Peak	dBV <sub>pk</sub>	dB
	RMS	dBV <sub>rms</sub>	dB
	Power	dBm	dB
MeasLog	N/A	dB	dB
MeasLin	N/A	Without Unit	Without Unit
MeasReal	N/A	Without Unit	Without Unit
MeasImag	N/A	Without Unit	Without Unit
MeasPhase	N/A	°	°
MeasPhaseUnwrap	N/A	°	°
MeasIQ	N/A	Without Unit	Without Unit
MeasCons	N/A	Without Unit	Without Unit
MeasEye	N/A	Without Unit	Without Unit
MeasQEye	N/A	Without Unit	Without Unit

Display View Type	Y Axis Unit Type	Ref Value	Scale/Div
MeasSpectrum	N/A	dB	dB
RefLog	N/A	dB	dB
RefLin	N/A	Without Unit	Without Unit
RefReal	N/A	Without Unit	Without Unit
RefImag	N/A	Without Unit	Without Unit
RefPhase	N/A	°	°
RefPhaseUnwrap	N/A	°	°
RefIQ	N/A	Without Unit	Without Unit
RefCons	N/A	Without Unit	Without Unit
RefIEye	N/A	Without Unit	Without Unit
RefQEye	N/A	Without Unit	Without Unit
RefSpectrum	N/A	dB	dB
EVMErrorTime	N/A	%	%
EVMErrorSpectrum	N/A	dB	dB
MagError	N/A	dB%	dB%
PhaseError	N/A	°	°

#### 5.1.3.4 Scale/Div

Sets the Y scale per division of the selected trace. The scale value is displayed at the graticule top.



#### NOTE

The default value of the Y scale and its unit are different for the different trace data. For details, refer to *Scale/Div of Y Axis*.

#### 5.1.3.5 Reference Pos

Click or tap **Ref Position** to set the amplitude reference position to "Top", "Center", or "Bottom".

5.1.3.6 Y Axis Unit

Sets the Y axis unit to "Power", "RMS", or "Peak".

Key Points:

The Y Axis Unit is available to choose when the data source is "RawTime" or "Spectrum". When the Y axis unit is set to "Peak", its unit is dBV<sub>pk</sub>; when the Y axis unit is set to "RMS", its unit is dBV<sub>rms</sub>; when the Y axis unit is set to "Power", its unit is dBm. After a unit is selected, the instrument will process the signal data according to the currently selected unit. At this time, you can observe the changes of the trace in the selected trace window, but the display of the graticule scale remains unchanged.

5.1.3.7 Last Scale

Sets Y Scale to the last modified Y-axis reference value and scale.

5.1.3.8 Copy Y Scale

Copies the Y scale setting of the currently selected view to all of other views that have the same Y-axis dimension. The available views include "Capture Data", "Meas Signal", "Ref Signal", and "Demod Error". For detailed view selection, refer to *Select the Display View*.



NOTE

The copy Y scale operation is valid when the dimension of the Y scale is the same as that in the specified measurement trace view; otherwise, the copy Y scale operation will be invalid.

5.2 Sweep and Function Settings

5.2.1 BW

5.2.1.1 FFT Window

Sets the type of the FFT window function.

Four FFT window types are available: Rectangular, Hanning, Gaussian, and Flattop.

You can select a proper filter type by referring to the following table according to the actual measurement requirements.

Window Function	Characteristics	Application
Rectangular	Its main lobe is relatively concentrated, but its side lobe is	If you have a high requirement on the accuracy

Window Function	Characteristics	Application
	relatively high, with negative side lobes. This will result in high-frequency interference and leakage during transform, even worse, the negative spectrum. The frequency recognition accuracy is the highest, and the amplitude recognition accuracy is the lowest.	of the frequency readout of the main lobe, without needing to consider the accuracy of the amplitude, then the rectangular window is recommended.
Hanning	It is also called the cosine window. Its main lobe is widened and lowered, and its side lobe is reduced significantly. In terms of leakage reduction, the Hanning window is superior to the Rectangular window. However, the wide main lobe of the Hanning window signifies the widened analysis bandwidth and reduced frequency resolution. Compared with the Rectangular window, the leakage and fluctuation of the Hanning window are reduced, with more choices.	The Hanning window is preferred under the following conditions: the signal under test has several frequency components; the spectrum is very complex; the test aim focuses more on the frequency point rather than the energy size; the signal under test is random or unknown.
Gaussian	It is an exponential window. Its main lobe is wide and frequency resolution is low. It has no negative side lobe, and the attenuation of its first side lobe reaches -55dB. It is often used to truncate some non-periodic signals, such as the exponential decay signal.	For the time-varying exponential decay function, you can use the exponential window to improve the S/N ratio.
Flattop	The flattop window has few low pass band fluctuations in the frequency domain.	As there are minor errors in the amplitude, this window can be used in calibration.

## 5.2.2 Sweep

Sets the sweep-related parameters.

### 5.2.2.1 Sweep Settings

---

#### Sweep Mode

Sets the current sweep mode to Single or Continuous.

#### Restart

When the sweep is Single, click or tap this menu, the sweep measurement is restarted for one single time. When the sweep is Continuous, this menu is disabled and grayed out.

## 5.2.3 Trigger

---

Selects the trigger source and sets trigger-related parameters.

### 5.2.3.1 Trigger Source

---

Sets "Free Run", "External", or "IF Power" to be the trigger source.

### 5.2.3.2 Free Run

---

The trigger conditions are met at any time, that is, the analyzer generates trigger signals continuously.

### 5.2.3.3 External Trigger

---

Click or tap **Trigger** > **Source** > **External**, then an external signal is input via the [TRIG IN] connector on the rear panel. When the signal meets the set trigger conditions, trigger signals are generated.



#### NOTE

The input signal frequency on the external trigger interface should not be greater than 1 MHz.

#### 1. Slope

Sets the trigger polarity for External Trigger. It is set positive to trigger on a rising edge and negative to trigger on a falling edge.

#### 2. Delay State

Enables or disables the trigger delay function. After the trigger delay function is enabled, you can set the trigger delay time.

#### 3. Delay Time

Sets the time interval during which the instrument waits to start the sweep operation after the trigger signal that meets the trigger conditions is generated.

You can use the numeric keys, the knob, or arrow keys to modify this parameter; you can also use the touch screen to modify the parameter.

Parameter	Remarks
Default	1 $\mu$ s
Range	-500 ms <sup>[1]</sup> to 500 ms
Unit	s, ms, $\mu$ s, ns, ps
Knob Step	trigger delay/100, Min = 1 $\mu$ s
Left/Right Arrow Key Step	at 1-1.5-2-3-5-7.5 step



#### NOTE

[1]: When the trigger delay is set to a negative value, it indicates a pre-trigger.

#### 5.2.3.4

#### IF Power Trigger

A trigger signal will be generated when the system detects a IF signal whose power level exceeds the specified trigger level.

##### 1. Trigger Level

Sets the trigger level of the IF power trigger. When the signal meets the set trigger level value, a trigger occurs.

Parameter	Remarks
Default	-25 dBm
Range	(-140+Level Offset) to (30+Level Offset)
Unit	dBm, -dBm, V, mV, $\mu$ V
Knob Step	1 dBm
Left/Right Arrow Key Step	5 dBm

##### 2. Delay State

Enables or disables the trigger delay function. After the trigger delay function is enabled, you can set the trigger delay time.

##### 3. Delay Time

Sets the time interval during which the instrument waits to start the sweep operation after the trigger signal that meets the trigger conditions is generated.

You can use the numeric keys, the knob, or arrow keys to modify this parameter; you can also use the touch screen to modify the parameter.

Parameter	Remarks
Default	1 $\mu$ s
Range	-500 ms <sup>[1]</sup> to 500 ms
Unit	s, ms, us, ns, ps
Knob Step	trigger delay/100, Min = 1 us
Left/Right Arrow Key Step	at 1-1.5-2-3-5-7.5 step

#### NOTE

[1]: When the trigger delay is set to a negative value, it indicates a pre-trigger.

#### 5.2.3.5 Trigger Holdoff State

Click or tap the ON/OFF tab for "Holdoff State" to enable or disable the trigger hold-off state.

#### 5.2.3.6 Trigger Holdoff

Sets the holdoff time between trigger signals. You can use the numeric keys, the knob, or arrow keys to modify this parameter; you can also use the touch screen to modify the parameter.

When the trigger conditions are met, the trigger occurs. Then, the delay begins, and the holdoff time begins. During the holdoff time, new trigger signals will be ignored. For a free-running trigger, the holdoff value is the minimum time between two trigger signals.

Parameter	Remarks
Default	100 ms
Range	0 us to 500 ms
Unit	s, ms, us, ns, ps
Knob Step	trigger holdoff time/100, Min = 1 us
Left/Right Arrow Key Step	at 1-1.5-2-3-5-7.5 step

#### 5.2.3.7 Auto Trig State

Enables or disables the auto trigger function.

### 5.2.3.8 Auto Trig

Sets the time that the instrument will wait for the trigger conditions to be met. When the set waiting time times out, the instrument will not wait and start to initiate the sweep measurement.

Parameter	Remarks
Default	100 ms
Range	1 ms to 100 s
Unit	s, ms, us, ns, ps
Knob Step	auto trigger time/100, Min = 1 us
Left/Right Arrow Key Step	at 1-1.5-2-3-5-7.5 step

The relationship of the trigger parameters is shown in the following figure.

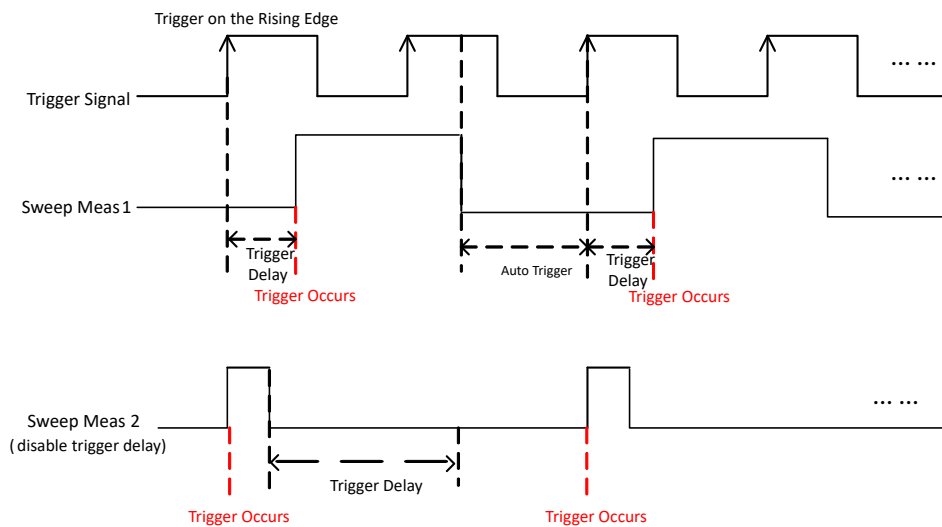

Figure 5.2 Relationship of Trigger Parameters

## 5.3 Measurement Settings

### 5.3.1 Meas Setup

Press **Meas Setup** to enter the measurement setup menu.

5.3.1.1 Setting

**Modulation Format**

**1. QAM**

The available QAM formats include 16QAM, 32QAM, 64QAM, 128QAM, 256QAM, 512QAM, and 1024QAM.

**2. PSK**

The available PSK formats include BPSK, QPSK, OQPSK (Offset QPSK), DQPSK, 8PSK, pi/4-DQPSK, pi/8-D8PSK, and D8PSK.

**3. FSK**

The available FSK formats include 2FSK, 4FSK, and 8FSK.

**4. MSK**

The available MSK formats include MSK1 and MSK2.

**5. ASK**

The available ASK formats include 2ASK and 4ASK.

**Meas Interval**

Sets the number of symbols for analysis in digital demodulation.

Parameter	Remarks
Default	50
Range	10 to 4,096
Unit	None
Knob Step	1
Left/Right Arrow Key Step	10

**Symbol Rate**

Sets the symbol rate for the analyzer's digital demodulator to match the symbol rate of the system.

In the digital demodulation, the symbol rate determines how often the symbols occur. The number of bits represented by each symbol is determined by the current modulation format. For example, in a BPSK system, each symbol represents 1 bit; in a QPSK system, each symbol represents 2 bits.

Parameter	Remarks
Default	1 Msps

Parameter	Remarks
Range	1 ksps to SRmax <sup>[1]</sup>
Unit	Gsps, Msps, ksps, and sps
Knob Step	100 sps
Left/Right Arrow Key Step	1 ksps



#### NOTE

[1]: Max. Symbol Rate SRmax = SPmax x 1.28/(Points/Symbol). Wherein, SPmax indicates the max span. SPmax is 80 MHz when the option RSA6000-B200 is not installed. SPmax is 200 MHz when the option RSA6000-B200 is installed.

#### Points/Symbol

Sets the number of points to be displayed for each symbol in the demodulation data within the displayed time. The available values are 4, 8, and 16.

#### Meas Filter

Sets the measurement filter type, i.e., the filter required for the demodulation of the vector modulation signal. It includes "None", "RRCosine", "Gaussian", "Rectangle", and user-defined value ("User Data1" through "User Data6").

Key Points:

- You can modify Alpha/BT to define the shape and width of the cosine and Gaussian filter.
- You can click or tap **Meas Setup** > **Meas Filter** to select User Data1 through User Data6 to define the specified filter. You can view the current data in the displayed user-defined filter setting interface. Click or tap **OK** to confirm selecting the specified filter. Click or tap **Cancel** to cancel the user-defined filter. Click or tap **Import Data** to import the specified measurement filter.

#### Reference Filter Type

Sets the refer filter type, i.e., the filter required for constructing the reference digital modulation signal. It includes "RCosine", "RRCosine", "Gaussian", "Rectangle", "Half Sine", and user-defined value ("User Data1" through "User Data6").

- You can modify Alpha/BT to define the shape and width of the cosine and Gaussian filter.
- You can click or tap **Meas Setup** > **Ref Filter** to select User Data1 through User Data6 to define the specified reference filter. You can view the current data in the displayed user-defined filter setting interface. Click or tap **OK** to confirm selecting the specified filter. Click or tap **Cancel** cancel the user-defined filter. Click or tap **Import Data** to import the specified filter.

### Alpha/BT

This parameter specifies the characteristics of the RCosine, RRCosine, and Gaussian filter used in the spectrum's digital demodulator. This parameter applies to the measurement filter and the reference filter. Its range is from 0.05 to 100.

#### 5.3.1.2

### Burst/Sync Search

**Sets the search parameters for the current measurement.**

#### 1. Burst Search

Enables or disables the Burst Search function.

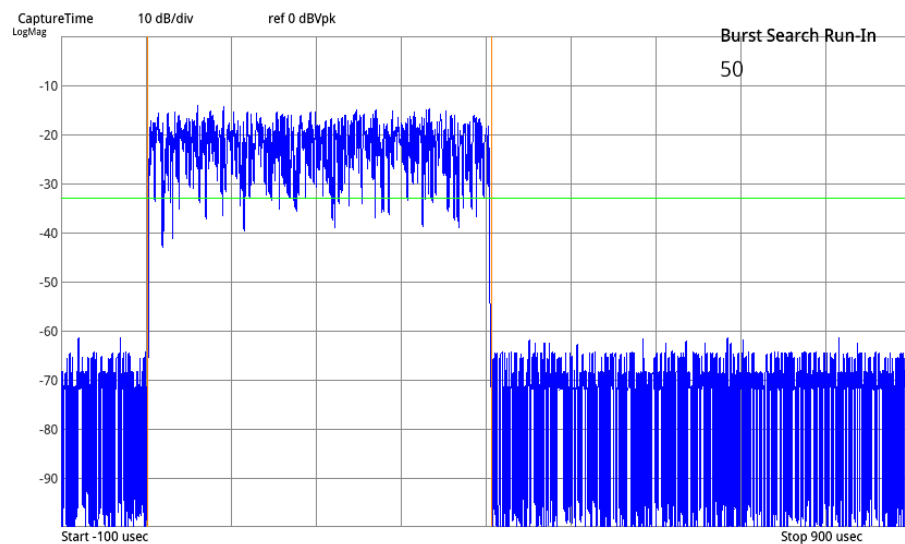

**Figure 5.3 Relationship of Burst Search Parameters**

#### 2. Burst Search Length Auto

Enables or disables the Burst Search Length Auto Mode function.

#### 3. Burst Search Length

Sets the burst search length. This menu is only valid when the Burst Search function is enabled.

Parameter	Remarks
Default	3 ms
Range	60 $\mu$ s to 65.536 ms
Unit	ms, $\mu$ s, ns, ps
Knob Step	1 $\mu$ s
Left/Right Arrow Key Step	10 $\mu$ s

#### 4. Burst Search Run-in

Sets the interference signal length to be removed when the instrument searches the burst rising edge. This menu is only valid when the Burst Search function is enabled.

Parameter	Remarks
Default	0
Range	0 to 16384
Knob Step	1
Left/Right Arrow Key Step	1

#### 5. Sync Search

Enables or disables the sync search function.

#### 6. Sync Analysis Length

Sets the number of symbols for analysis in Sync Search. This menu is only valid when the Sync Search function is enabled.

Parameter	Remarks
Default	200
Range	50 to 4,096
Knob Step	1
Left/Right Arrow Key Step	10

#### 7. Sync Offset

Sets the the number of symbols between the start of the measurement data and the start of the sync word.

Parameter	Remarks
Default	0

Parameter	Remarks
Range	0 to 4,096
Knob Step	1
Left/Right Arrow Key Step	10

**8. Sync Pattern**

Sets the bit pattern for the sync search. Click or tap **Sync Pattern**, the sync pattern interface is displayed, as shown in the figure below.

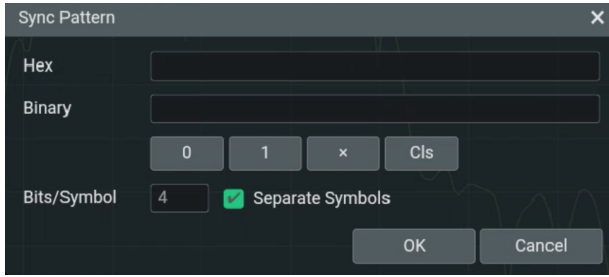

**Figure 5.4 Sync Pattern**

Click or tap 0 or 1 to input the binary value into the input field of "Binary". The hex input field displays the hex format. The input field of "Bits/Symbol" displays the number of bits per symbol in the currently selected demodulation format. Check or uncheck the checkbox of "Separate Symbol" to separate or unseparate the data in its Binary or Hex format. Click or tap **OK** to confirm the settings. Click or tap **Cancel** to cancel the settings.

**5.3.1.3 BER**

**BER**

**BER**

Click or tap the ON/OFF tab for **BER** to enable or disable BER. When enabled, the system will load the known data, and compare it with the signal under test bit by bit. Then calculate the ratio of the number of error bits to the total number of bits.

Click or tap **Known Data**, and the file management interface is displayed. Select the desired BER test file to be loaded, then click or tap **Confirm** to confirm loading the file.

**The BER file shall meet the following formats.**

Format Requirement	Range	Description
<RIGOL_VSA_KNOWN_D ATA_FILE Version="01.00">	--	File Header

Format Requirement	Range	Description
<Comment> </Comment>	Available modulation types	--
<Base> </Base>	2 16	Used to specify the format of the <Data> value. It can be set to Binary format or Hex Format.  When <ModulationOrder> ≥ 32, use the Binary format.
<ModulationOrder> </Modulation-Order>	2 4 8 16 32 64 128 256	Indicates the number of different symbols (modulation order) that can be transmitted under the selected modulation type. For example, 8-PSK indicates the PSK modulation order is 8.  <ModulationOrder> ≥ 32, <Base> = 2.
<ResultLength> </ResultLength>	1 to 2,000 <sup>[1]</sup>	Indicates the number of symbols included in each <Data> value.
<Data> </Data>	Indicates a byte of each symbol in the modulation order. The range of the number of bytes is from 0 to (n-1). Wherein, n indicates <ModulationOrder>. Space, tab, and line break can be omitted.	Indicates a symbol order that can be demodulated from the input signal.  <Data> can be set to up to 6,000 <sup>[1]</sup> different orders.
</RIGOL_VSA_KNOWN_DATA_FILE>	--	Indicates the file end.

**NOTE**

[1]: determined by the available memory space.

**The sample of the BER xml file is as follows:**

```
<RIGOL_VSA_KNOWN_DATA_FILE Version="01.00">
```

```

<Comment> Standard 8PSK </Comment>
<Base> 16 </Base>
<ModulationOrder> 8 </ModulationOrder>
<ResultLength> 148 </ResultLength>
<Data> 777 511 727 242 206 341 366 632 073 607
770 173 705 631 011 235 507 476 330 522
177 177 171 117 777 177 717 717 111 615
527 046 104 004 106 047 125 415 723 344
241 264 773 111 337 446 514 600 677 7 </Data>
</RIGOL_VSA_KNOWN_DATA_FILE>

```

### Total Bits

Used to control the total number of bits displayed in the demodulation bit order interface.

### Ref Bits

Click or tap the ON/OFF tab for **Ref Bits** to enable or disable the reference bits.

### Symbol Format

Sets the display format of the symbol data. You can select "Hex" or "Bin".

### NOTE

Only when you select the "Demod Bits" view, can this menu be available.

#### 5.3.1.4

### Pre-demod

Click or tap **Preset To Standard** to select the preset digital demodulation setup parameters and span to measure a variety of standard digital communications formats. The available choices include "NONE", "Cellular", "Wireless", and "Other".

- Cellular: GSM, NADC, WCDMA, PDC, and PHP.
- Wireless: BLUETOOTH, WLAN802, ZIGBEE 868M, ZIGBEE 915M, and ZIGBEE 2450M.
- Other: TETRA, DECT, and APCO-25.

#### 5.3.1.5

### Global CF Mode

#### 1. Global CF Mode

Turns on or off the global center frequency. In any working mode, if you enable the global center frequency mode, then the global center frequency will be set to the center frequency of the current mode. When a different working mode is selected, the global center frequency will be set to the center frequency of the previous working mode, that is, the one that is before switching the working mode. If you change the center frequency in any working mode, then the global center frequency will change with it.

## 2. Global CF

Sets the global center frequency. It is only available when you enable the global CF mode.

## 5.4 Marker

### 5.4.1 Marker Setting

Marker is used for marking the point on the trace. Through the marker, you can read the X-axis and Y-axis readouts of the point on the trace.

Key Points:

- RSA6000 offers 8 markers in VSA mode, and only a single marker or one pair of markers can be turned on each time.
- The marker readout will be displayed at the upper-right corner of the marker trace view.
- In the Marker menu, you can use the numeric keys, the knob, or the arrow keys to modify X-axis readout; to view the readout of different points on the trace.

You can also use the touch screen to do the above things.

#### 5.4.1.1 Selected Marker

RSA6000 provides 8 markers. By default, Marker1 is selected under "Selected Marker". After you select a marker, you can set parameters such as the marker mode and the marker trace. The currently enabled marker will be marked on the selected marker trace.

#### 5.4.1.2 Next Marker

Click or tap **Next Marker** to select the next enabled marker.

### 5.4.1.3 Marker Mode

---

Sets the type of the marker. The available marker modes include Position, Delta, Fixed, and OFF.

#### 1. Position

It is used to measure the X and Y values of a certain point on the trace. When "Position" is selected, a marker indicated by a number (e.g., "1") appears on the trace.

Key Points:

- When the currently selected display view is not consistent with the one selected for the marker trace, then the marker will be opened in the currently selected display view, and the marker trace will be changed accordingly.
- If no active marker exists currently, a marker will be enabled in the center of the X-axis of the current trace.

#### 2. Delta

It is used to measure the difference between "reference point" and "certain point on the trace": X value and Y value. When "Delta" is selected, a pair of markers appears on the trace: Reference Marker (marked by "X") and the Delta Marker (marked by " $\Delta$ ").

Key Points:

- If an active marker exists currently, then activate a reference marker at the current marker; otherwise activate both the reference marker and Delta marker at the same time in the center of X-axis of the current trace.
- When you change the position of the Delta marker, the position of the reference marker remains unchanged, but the Delta between the two markers will change along with it.

#### 3. Fixed

When you select "Fixed" marker, you can directly or indirectly set the X-axis and Y-axis values for the marker. Once specified, its position remains unchanged, and its Y-axis value does not change along with the trace. The fixed marker is generally used as the reference marker for the Delta marker. It is indicated by the sign "x".

#### 4. OFF

Turns off the marker currently selected. Then, the marker information displayed on the screen and the functions concerning the marker will also be disabled.

#### 5.4.1.4 Reference Marker

---

Sets the reference marker for the current marker. By default, the reference marker is the marker next to it.

Key Points:

- Each marker can have another marker to be its reference marker.
- If the current marker is a Delta marker, the measurement result of the marker will be determined by the reference marker.
- Any marker cannot take itself to be the reference marker.

#### 5.4.1.5 Marker Trace

---

Selects the trace that the current marker marks. The available trace types include "Capture Data", "Meas Signal", "Ref Signal", and "Demod Error". For detailed display views, refer to *Select the Display View*.

#### 5.4.1.6 Marker X

---

Sets the X-axis readout of the marker to change the position of the marker on the trace. Click or tap this menu to modify the value to change the position of the marker.

Key Points:

- If the marker mode is set to Position or Fixed, this value sets the X value at the marker.
- If the marker mode is set to Delta, this value sets the X value of the Delta marker in relative to that of the reference marker.
- When "Fixed" is selected for the marker mode and the marker is in the constellation or I-Q view, Marker X is used to locate the data points.

#### 5.4.1.7 Marker Y

---

When the marker mode is set to "Fixed", you can click or tap this menu to set the Y value of the current marker.

**NOTE**

When you select the fixed marker mode and the marker is in the constellation or IQ view, Marker Y is used to set the marker's in-phase component (real part) of the Y value.

**5.4.1.8 Marker Y Image**

---

When "Fixed" is selected for the marker mode and the marker is in the constellation or I-Q view, Marker Y is used to set the marker's quadrature component (imaginary part) of the Y value.

**5.4.1.9 Couple Markers**

---

Enables or disables the marker coupling function.

Key Points:

- When this function is enabled, moving any marker will enable other markers (except the Fixed or Off marker) to move with it.
- The fixed marker does not move along with other marker, but if the fixed marker moves, other non-fixed markers will move with it.

**5.4.1.10 All Markers Off**

---

Turns off all the enabled markers and their related functions.

**5.4.2 Marker To**

---

Use the current marker settings to set other system parameters, such as center frequency, reference level, and etc.

**5.4.2.1 Mkr->CF**

---

Sets the center frequency of the analyzer to the frequency of the current marker.

- If Position marker is selected, the center frequency will be set to the frequency of the current marker.
- If Delta marker is selected, the center frequency will be set to the frequency of the Delta marker.
- This function is only valid in the Spectrum view, MeasSpectrum view, RefSpectrum view, and EVMErrorSpectrum view.

#### 5.4.2.2 Mkr->Step

---

Sets the center frequency step of the analyzer to the frequency of the current marker.

- If Position marker is selected, the center frequency step will be set to the frequency of the current marker.
- If Delta marker is selected, the center frequency step will be set to the frequency difference between the Delta marker and the reference marker.
- This function is only valid in the Spectrum view, MeasSpectrum view, RefSpectrum view, and EVMErrorSpectrum view.

#### 5.4.2.3 Mkr->Ref

---

Sets the reference level of the analyzer to the amplitude of the current marker.

- If Position marker is selected, the reference level will be set to the amplitude of the current marker.
- Given a Delta marker, if the current marker is the reference marker, then the reference level is set to the amplitude of the reference marker; if the current marker is the Delta marker, then the reference level is set to the amplitude of the Delta marker.

#### 5.4.2.4 Marker $\Delta$ ->CF

---

Sets the center frequency of the analyzer to the frequency difference between the two Delta markers.

This function is only valid in the Spectrum view, MeasSpectrum view, RefSpectrum view, and EVMErrorSpectrum view.

This function is only valid when the Delta marker is selected.

### 5.4.3 Marker Function

---

#### 5.4.3.1 Band Function

---

The band function defines the corresponding parameters for a frequency band measurement signal at the marker point.

##### 1. Band Power

Calculates the total power within a certain band.

## 2. OFF

Disables the band function.

Disabling the band function will neither affect the frequency band parameters nor disable the marker.

### 5.4.3.2 Band Setting

---

Adjusts the band parameter for the band function.

#### 1. Band Span

Sets the bandwidth of the signal involved in the calculation for the band function.

#### 2. Band Left

Sets the left edge frequency of the signal involved in the calculation for the band function.

#### 3. Band Right

Sets the right edge frequency of the signal involved in the calculation for the band function.



#### NOTE

The band function is available for the Spectrum view, MeasSpectrum view, RefSpectrum view, and EVMErrorSpectrum view.

## 5.4.4 Peak Search

---

The peak search function enables the marker to move to the specific signal peak point, and then in combination with the function of Delta marker, it can provide a powerful analysis capability.

### 5.4.4.1 Peak Search

---

Performs the peak search function. Searches for the maximum value on the trace and marks it with a marker.

### 5.4.4.2 Next Peak

---

Searches for and marks the peak whose amplitude on the trace is next lower than that of the current peak.

#### 5.4.4.3 Next Higher

Searches for and marks the peak whose amplitude on the trace is next higher than that of the current peak.

#### 5.4.4.4 Next Peak Right

Searches for and marks the peak closest to the right side of the current peak.

#### 5.4.4.5 Next Peak Left

Searches for and marks the peak closest to the left side of the current peak.

#### 5.4.4.6 Minimum Search

Searches for and marks the peak with the minimum amplitude on the trace.

#### 5.4.4.7 Continuous Peak

Enables or disables continuous peak search. By default, it is OFF. When it is enabled, after finishing each sweep, the analyzer will automatically execute one peak search operation to track the measurement signal.

## 5.5 Input/Output

Sets the input/output interface.

### 5.5.1 Input Impedance

Sets the input impedance for voltage-to-power conversions. The default input impedance is 50  $\Omega$ . To measure a 75  $\Omega$  device, you should use a 75  $\Omega$  to 50  $\Omega$  adapter (option) supplied by RIGOL to connect the analyzer with the system under test, and then set the input impedance to 75  $\Omega$ .

### 5.5.2 Ext Gain

Compensates for gain or loss in the measurement system outside the instrument.

Remarks:

- This value can change the trace position, but will not change the Y-axis reference value and scale.
- You can use the numeric keys, the knob, or arrow keys to modify this parameter; you can also use the touch screen to modify the parameter.

Parameter	Remarks
Default	0 dB
Range	-120 dB to 120 dB
Unit	dB
Knob Step	1 dB
Left/Right Arrow Key Step	1 dB

### 5.5.3 Trig Out

#### Enable or Disable the Trigger Output

Select to enable or disable the trigger output.



#### Set the Trig Out Polarity

Select the trigger output as "Positive" or "Negative".

## 5.6 Shortcut Key

### 5.6.1 Preset

Recalls the preset setting and restores the system settings of the analyzer to a specified status.

Press  on the front panel to restore the factory default settings. You can also click or tap  at the upper-right corner of the screen to recall the factory settings. The following table lists the factory default settings (except items specified in Note [3]) or user-defined settings.

Parameter Name	VSA Parameter
<b>Frequency</b>	
Center Frequency	13.25 GHz
CF Step	Auto, 312.805 kHz
<b>Amplitude</b>	
Range	0 dBm

Parameter Name	VSA Parameter
Ref Value <sup>[1]</sup>	10 dBm
Y Axis Unit <sup>[1]</sup>	Power
Copy Y Scale <sup>[1]</sup>	Spectrum
Scale/Div <sup>[1]</sup>	10 dB
Ref Position <sup>[1]</sup>	Top
<b>Bandwidth</b>	
FFT Window	Flattop
<b>Sweep</b>	
Sweep Mode	Continuous
<b>Trigger</b>	
Trigger Source	Free Run
Trigger Holdoff	OFF, 100 ms
Auto Trig	OFF, 100 ms
Slope	POS
Trigger Delay	OFF, 1 $\mu$ s
Trigger Level	-25 dBm
<b>Measure Setup<sup>[2]</sup></b>	
Global CF	
Global CF	OFF, 13.25 GHz
Setting	
Mod Format	2ASK
Meas Interval	50
Symbol Rate	1 Msps
Points/Symbol	4

Parameter Name	VSA Parameter
Measurement Filter	RRCosine
Reference Filter	RCosine
Alpha/BT	0.35
Burst/Search	
Burst Search	OFF
Burst Search Length	OFF, 3 ms
Burst Search Run-in	0
Sync Search	OFF
Sync Analysis Length	200
Sync Offset	0
Sync Pattern	-
BER	
BER	OFF
Total Bits	200
Ref Bits	OFF
Symbol Format	Bin
Preset	
Preset To Standard	NONE
<b>Marker</b>	
Marker Setup	
Selected Marker	Marker 1
Marker Mode	OFF
Reference Marker	Marker 2
Marker Trace	Spectrum

Parameter Name	VSA Parameter
Marker X	0 Hz
Couple Markers	OFF
<b>Function</b>	
Band Span	OFF, 156.403 kHz
Band Left	13.249929658 GHz
Band Right	13.250086061 GHz
<b>Peak Search</b>	
Cont Peak	OFF
<b>Display</b>	
X Scale <sup>[1]</sup>	ON
Ref Value <sup>[1]</sup>	0 Hz
Width <sup>[1]</sup>	3.128054 MHz
Ref Position <sup>[1]</sup>	Left
Copy X Scale <sup>[1]</sup>	Spectrum
Eye Length <sup>[1]</sup>	2
Comb View	Normal
<b>Input/Output</b>	
Input Impedance	50 $\Omega$
Ext Gain	0 dB
Trig Out	OFF
Trig Out Polarity	Positive
<b>System<sup>[3]</sup></b>	
Power On	Preset
Power Switch	OFF

Parameter Name	VSA Parameter
Beeper	OFF
Screen Brightness	80%
Fan Speed	56%
Display Time	ON
Auto Calibrate	OFF
Language	English



**NOTE**

- [1]: Take Spectrum view as an example.
- [2]: This function is only available for RSA6000 installed with the corresponding option.
- [3]: Not affected by Preset settings.

### 5.6.2 Single/Continue

Press  to set the sweep mode to Single or Continuous. For detailed setting methods, refer to the descriptions in *Sweep Mode*.

### 5.6.3 Restart

Press  to restart to sweep. After performing this operation, the sweep or measurement is restarted. The Restart operation aborts the current sweep or measurement. It resets the sweep and trigger systems. All the previously measured data will be remeasured.

## 5.7 System Utility Function Setting

### 5.7.1 System

Sets the system parameters.

#### 5.7.1.1 I/O Setting

The analyzer supports the LAN or USB communication interface. In the **System** menu, click or tap **I/O** to enter the I/O setting menu to configure the following parameters.

## Network Status

Different prompts will be displayed according to the current network connection status.

- DISCONNECTED!
- CONNECTED

## MAC Address

The MAC address of each oscilloscope is unique. When assigning the IP address for the oscilloscope, the system uses the MAC address to identify the instrument.

## VISA Address

Displays the VISA address currently used by the the instrument.

## IP Configuration Type

The configuration type of the IP address can be DHCP, Auto IP, or Static IP. In different IP configuration types, the configurations for IP address and other network parameters are different.

- **DHCP**

If "DHCP" is selected, the DHCP server in the current network will assign the network parameters (e.g. IP address, Subnet, Gateway, and DNS) for the the instrument.

- **Auto IP**

When "Auto IP" is selected, the instrument will acquire the IP address ranging from "169.254.0.1" to "169.254.255.254" and the subnet mask (255.255.0.0) automatically based on the current network configuration. The "Auto IP" works only when "DHCP" is not selected or connection is failed.

- **Static IP**

If "Static IP" is selected, the instrument is configured with static IP. In this case, you need to disable DHCP and Auto IP manually. At this time, you need to set the IP address, Subnet, Gateway, and DNS manually. At this time, you can self-define the network parameters (e.g. IP address) of the instrument.

- **Set the IP address**

The format of the IP address is nnn.nnn.nnn.nnn. The range of the first segment (nnn) of the address is from 0 to 255 (except 127); wherein, the valid range is from 0 to 223. The range for the other three segments is from 0 to 255. You are recommended to ask your network administrator for an IP address available.

This setting will be saved to the non-volatile memory; if "Power On" is set to "Last", then DHCP and Auto IP are disabled at the next power-on. The instrument will load the preset IP address automatically.

- **Set the subnet mask**

The format of the subnet mask is nnn.nnn.nnn.nnn. Wherein, the range of "nnn" is from 0 to 255. You are recommended to ask your network administrator for a subnet mask available.

This setting will be saved in the non-volatile memory; if "Power On" is set to "Last", then DHCP and Auto IP are disabled at the next power-on. The instrument will load the preset subnet mask automatically.

- **Set the default gateway**

You can set this parameter in Static IP mode. The format of the gateway is nnn.nnn.nnn.nnn. The range of the first segment (nnn) is from 0 to 223 (except 127), and the range for the other three segments is from 0 to 255. You are recommended to ask your network administrator for a gate address available.

This setting will be saved to the non-volatile memory; if "Power On" is set to "Last", then DHCP and Auto IP are disabled at the next power-on. The instrument will load the preset gateway automatically.

- **Set the DNS address**

You can set this parameter in Static IP mode. The format of the DNS address is "nnn.nnn.nnn.nnn". The range for the first segment (nnn) of the address is from 0 to 223 (except 127); and the range for the other three segments is from 0 to 255. You are recommended to ask your network administrator for an address available.

Generally, you do not need to set the DNS, therefore this parameter setting can be ignored.



**TIP**

- When the three IP configuration types are all turned on, the priority of the parameter configuration from high to low is "DHCP", "Auto IP", and "Static IP".
- The three IP configuration types cannot be all turned off at the same time.

**mDNS**

Click or tap the ON/OFF tab for **mDNS** to enable or disable the multicast Domain Name System (mDNS). This system is used to provide the function of DNS server for service discovery in a small network without a DNS server.

**Host Name**

If mDNS is enabled, you need to configure the mDNS host name, supporting inputting a maximum of 26-byte strings.

### Apply the Network Parameter Setting

Click or tap **Apply** to validate the current network parameter setting.

### Reset the Communication Interface

Click or tap **Reset**, then the prompt message "Are you sure to reset interface settings" is displayed. Click or tap **Confirm** to confirm resetting interface settings.

## 5.7.1.2 Basic Settings

In the **System** menu, click or tap **Setup** to enter the basic setting menu.

### Language

This product supports menus in multiple languages. Both Chinese and English are available for the display of the help information, prompt messages, and interface. Click or tap the drop-down button of **Language** to select the specified system language from the drop-down list.

### Power On

You can set the system configuration to be recalled when the oscilloscope is powered on again after power-off. Click or tap "Preset" or "Last" for **Power On**.

- Last: returns to the setting of the system at last power-off.
- Preset: restores the system to its factory setting.

### Power Switch

- OFF: After the analyzer is connected to power, you need to press the Power key on the front panel to power on the instrument.
- ON: After the analyzer is connected to power, it will be powered on automatically.

### Beeper

Click or tap the ON/OFF tab for **Beeper** to enable or disable the beeper. When the beeper is enabled, you can hear the sound of the beeper when you perform the following operations:

- Press a key or a menu key on the front panel
- Enable the touch screen
- When a prompt message is displayed

### Screen Brightness

Drag the slide bar of **Screen Brightness** to set the screen brightness. Its settable range is from 0% to 100%.

### Fan Speed

Click or tap the slide bar at the right side of **Fan Speed** to set the fan speed of the instrument. Its settable range is from 0% to 100%.

### Display Time

Click or tap the ON/OFF tab for **Display Time** to enable or disable the display of the system time.

The system time (date and time) is displayed in the Notification Area at the lower-right corner of the screen. The date is displayed in "yyyy/mm/dd" format, and the time is displayed in "hh:mm:ss" format. When you save the waveform, the output file will contain the time information. Users can set the system time.

- **Date:** Click or tap the "Date" area, then the date setting interface is displayed. Select a proper date, then click or tap **Confirm** to confirm the date modification.
- **Time:** Click or tap the "Time" area, then the time setting interface is displayed.
  - Click or tap the Hour/Minute number and then drag the hour/minute hand to modify the time.
  - After setting, click or tap **Confirm** to confirm the setting.

#### 5.7.1.3 About this Spectrum

In the **System** menu, click or tap **About**, and then you can view the model, version, and other information about this spectrum analyzer in **About** menu.

- **Model**  
Indicates the product model.
- **Serial number**  
Indicates the serial number of the product, the unique identification for the product.
- **Firmware**  
Indicates the firmware version number of the product.
- **Hardware**  
Indicates the hardware version number of the product.
- **Build**  
Indicates the creation time for the software version.
- **Android.Build**  
Indicates the creation time of the Android operating system.
- **Android.Version**

Indicates the version number of the Android operating system. For example, 7.1.0.

- **Launcher**

Indicates the desktop UI version number of the Android operating system.

- **WebControl**

Indicates the version number of browser remote control module.

- **Upgrade**

Click or tap **Upgrade**, and the file management interface is displayed. Select the desired upgrade file to upgrade the system. For detailed operations, refer to the descriptions in *Update*.

#### 5.7.1.4 Options

---

In the "System" menu, click or tap **Options**, then all the options that have currently been installed can be displayed. For the procedures of installing the option, refer to descriptions in *To View the Option and the Option Installation*.

#### 5.7.1.5 Calibration

---

##### 1. Calibrate Now

Click or tap this menu, and the analyzer will use the internal calibration source to perform the self-calibration immediately.

##### 2. Auto Calibrate

Enables or disables auto self-calibration. If auto self-calibration is enabled, the analyzer will perform one self-calibration after it is launched.

### 5.7.2 File

---

RSA6000 series spectrum analyzer allows you to save various types of files to the internal or external memory, and recall them when necessary.

Click or tap  > **File** to enter the file management interface.

#### 5.7.2.1 File Management

---

Click or tap **File** to enter the file management interface. You can touch the screen or use the mouse to click on the screen to select the corresponding file or folder. Displays all the files with the specified file types. When you select a file, you can click or tap **Rename**, **Cut**, **Copy**, **Paste**, **Cancel**, or **Delete** to perform the specified operation.

The available file types include: State, Measurement Data, and Screen Image. The descriptions for various file types are shown in the following table.

File Type	Format	Suffix Name
State	BIN	.sta
Measurement Data	CSV	.csv
Screen Image	IMAGE	.jpg/bmp/png



#### NOTE

RSA6000 can only recognize files whose filenames consist of Chinese characters, English letters, or numbers. If the filename or folder name contains strings other than the above mentioned characters, the file or the folder might not be displayed normally in the file manager interface.

#### 5.7.2.2 New Folder

Creates a folder under the current directory, and the file is named with a default filename. To modify this filename, click or tap **Rename** to rename the file.

#### 5.7.2.3 Rename

Renames a file that has been stored. After you select a file, click or tap this menu name to input a new filename.

#### 5.7.2.4 Cut

Cuts the currently selected file or folder from the specified path.

#### 5.7.2.5 Copy

Copies the currently selected file or folder.

#### 5.7.2.6 Paste

Pastes the file or folder.

When the current path has contained a file or folder whose name is the same as the one that you want to paste, after you perform the paste operation, the original file or folder will be overwritten.

#### 5.7.2.7 Delete

Deletes the selected file.

### 5.7.2.8 Security Clear

---

Click or tap **SecurityClear**, then a prompt message "Confirm SecurityClear?" is displayed. Click or tap **Confirm** to clear all the saved files from the internal memory. Click or tap **Cancel** to cancel security clear operation.

## 5.7.3 Recall

---

RSA6000 allows you to recall various types of files from the internal or external storage memory.

Click or tap  > **Recall** to enter the file recalling menu. The available file types include: State and Measurement Data.

### 5.7.3.1 State

---

Click or tap **State** to enter the state recalling menu. The state can be recalled from the register or the file.

#### 1. Load from File

Click or tap **Load from File** to enter the file management interface. Select a file and then click or tap **Confirm** to confirm loading the specified file.

#### 2. Register1 through Register16

When any one of the items from Register1 to Register16 is selected, the state of the specified register will be recalled.

### 5.7.3.2 Measurement Data

---

Click or tap **Meas Data** to enter the measurement data recalling menu.

#### 1. Load from File

Click or tap **Load from File** to enter the file management interface. Select a file and then click or tap **Confirm** to confirm loading the specified file.

#### 2. Measure Type

Selects the measurement data type to be loaded.

## 5.7.4 Save

---

RSA6000 allows you to save various types of files to the internal or external memory.

Click or tap  > **Save** to enter the file saving interface. The available file types include: State, Measurement Data, and Screen Image.

### 5.7.4.1 State

---

Click or tap **State** to enter the state saving menu. The state can be saved to the register or the file.

#### 1. Save to File

Click or tap **Save to File** to save the current state in the default filename or user-defined filename.

#### 2. Register1 through Register16

When any one of the items from Register1 to Register16 is selected, the current state of the instrument will be saved to the corresponding register. The register supports quick save and recalling instrument state. The register menu displays the time for saving the instrument state.

### 5.7.4.2 Preset

---

#### 1. Select Preset

Click or tap **Select Preset** to select the desired preset settings. The available choices include "Default", "User1", "User2", "User3", "User4", "User5", and "User6".

#### 2. Register1 through Register16

When any one of the items from Register1 to Register16 is selected, the current state of the instrument will be saved to the corresponding register. The register supports quick save and recalling instrument state. The register menu displays the time for saving the instrument state.

### 5.7.4.3 Measurement Data

---

Click or tap **Meas Data** to enter the measurement data saving menu. The selected measurement data type (raw data or measurement results) can be saved to the specified file. The data will be saved in .csv format. They are separated with a comma, and this is convenient for you to use the Excel to analyze the data.

#### 1. Save to File

Click or tap this menu to save the currently selected type of measurement data in the default filename or user-defined filename.

#### 2. Measure Type

Selects the measurement data type to be saved. The measurement data types supported by the instrument include raw data and measurement results.

#### 5.7.4.4 Screen Image

---

Click or tap **Screen** to enter the screen saving menu. You can also click or tap  on the quick operation toolbar to quick save the screen image.

##### 1. Save to File

Click or tap **Save to File** to save the current screenshot in the default filename or user-defined filename.

##### 2. Screenshot Info

###### a. Image Format

Click or tap Format to select the file format of the current screen image to be "\*.png", "\*.bmp", or "\*.jpg".

###### b. Invert

Click or tap the ON/OFF tab for **Invert** to enable or disable inverting the color of the current screen image.

#### 5.7.5 Update

---

This instrument supports local upgrade and online upgrade.

1. Click or tap  > **Update**, then the File Management interface is displayed. Select the update file. For detailed operations, refer to the descriptions in *File*.
2. Click or tap **Confirm** to complete the local upgrade.

#### 5.7.6 Help Menu

---

The built-in help file provides information about the functions and menu



introductions of the instrument. Click or tap  > **Help** to enter the help system.

You can get its help information by clicking on the link for the introduction of the specified function.

#### 5.7.7 Shutdown

---

- Click or tap the function navigation icon  at the lower-left corner of the screen to enter the function navigation. Click or tap **Shutdown** to shut down the instrument. Then, a prompt message "Are you sure to shutdown?" is displayed. Click or tap **Confirm** to confirming shutting down the instrument.

- Press down the power key , then a prompt message "Are you sure to shutdown?" is displayed. Click or tap **Confirm** to confirming shutting down the instrument.
- Press the power key  continuously for two times to turn off the instrument.
- Long press the power key  for three seconds to turn off the instrument.

### 5.7.8 Restart

Click or tap the function navigation icon  at the lower-left corner of the screen to enter the function navigation. Click or tap **Restart** to restart the instrument. Then, a prompt message "Are you sure to restart?" is displayed. Click or tap **Confirm** to restart the instrument.

## 6 Remote Control

The instrument can be remotely controlled in the following several methods:

- **User-defined Programming**

You can program and control the instrument by using the SCPI (Standard Commands for Programmable Instruments) commands. For details about the SCPI commands and programming, refer to *Programming Guide*.

- **Web Control**

This instrument supports Web Control. Connect the instrument to the network, then input the IP address of the instrument into the address bar of the browser of your computer. The web control interface is displayed. Click Web Control to enter the web control page. Then you can view the display of the real-time interface of the instrument. Through the Web Control, you can migrate the device control to the control terminals (e.g. PC, mobile phone, iPad, and other smart terminals) to realize remote control of the instrument.

This instrument can be connected to the PC via the USB HOST interface or LAN interface to set up communication and realize remote control. The remote control can be realized by using SCPI (Standard Commands for Programmable Instruments) commands.

This chapter will illustrate how to use the RIGOL Ultra Sigma software to remotely control the instrument via various interfaces.

### CAUTION

**Before setting up communication, please turn off the instrument to avoid causing damage to the communication interfaces.**



### 6.1 Remote Control via USB

#### 1. Connect the device

Use the USB cable to connect the rear-panel USB DEVICE interface of the instrument to the USB HOST interface of the PC.

#### 2. Search for the device resource

Start up Ultra Sigma and the software will automatically search for the resource currently connected to the PC via the USB interface. You can also click **USB-TMC** to search for the resource.

#### 3. View the device resource

The resources found will appear under the "RIGOL Online Resource" directory, and the model number and USB interface information of the instrument will also be displayed.

#### 4. Control the instrument remotely

Right-click the device resource name and select "SCPI Panel Control" to open the remotely command control panel. Then you can send commands and read data through the panel. For details about the SCPI commands and programming, refer to the Programming Guide of this instrument.

## 6.2 Remote Control via LAN

### 1. Connect the device

Use the network cable to connect the instrument to your local area network (LAN).

### 2. Configure network parameters

Configure the network parameters of the instrument in **Utility>IO** menu.

### 3. Search for Search device resource

Start up Ultra Sigma and click **LAN** to open the panel as shown in the figure below. Click **Search** and the software searches for the instrument resources currently connected to the LAN and the resources found are displayed at the right section of the window as shown in the figure below. Click **OK** to add it.

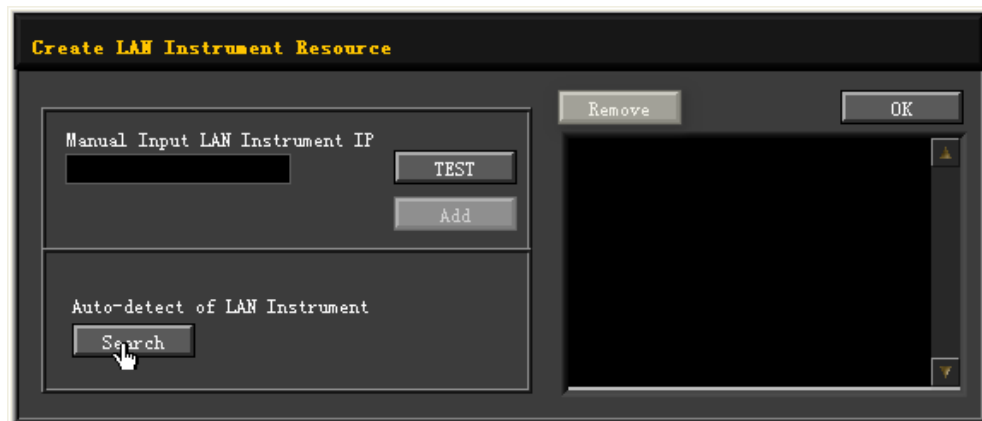

Besides, you can input the IP address of the instrument manually into the text field under "Manual Input LAN Instrument IP", then click **TEST**. If the instrument passes the test, click **Add** to add the instrument to the LAN instrument resource list in the right section; if the instrument fails the test, please check whether the IP address that you input is correct, or use the auto search method to add the instrument resource.

### 4. View the device resource

The resources found will appear under the "RIGOL Online Resource" directory.

### 5. Control the instrument remotely

Right-click the device resource name and select "SCPI Panel Control" to open the remotely command control panel. Then you can send commands and read data through the panel.

## 6. Load LXI webpage

As this instrument conforms to LXI CORE 2011 DEVICE standards, you can load LXI web page through Ultra Sigma (right-click the instrument resource name and select "LXI-Web"). Various important information about the instrument (including the model, manufacturer, serial number, description, MAC address, and IP address) will be displayed on the web page. You can also directly input the IP address of the instrument in the address bar of the PC browser to load the LXI web page.

## 7 Appendix

### 7.1 Appendix A: Options and Accessories

	Description	Order No.
Model	Real-time Spectrum Analyzer, 5 kHz to 8.5 GHz	RSA6085
	Real-time Spectrum Analyzer, 5 kHz to 14 GHz	RSA6140
	Real-time Spectrum Analyzer, 5 kHz to 26.5 GHz	RSA6265
Standard Accessory	Power Cord	-
Options	Vector Signal Analysis Application Software	RSA6000-VSA
	EMI Measurement Application Software	RSA6000-EMI
	Analog Demodulation Application Software	RSA6000-ADM
	Preamplifier (PA), 8.5 GHz	RSA6000-P08
	Preamplifier (PA), 14 GHz	RSA6000-P14
	Preamplifier (PA), 26.5 GHz	RSA6000-P26
	200 MHz Analysis Bandwidth	RSA6000-B200
	200 MHz Real-time Bandwidth	RSA6000-RB200
	Advanced Measurement Kit	RSA6000-AMK
	8.5 GHz Tracking Generator Output	RSA6000-T08
Optional Accessories	DSA utility kit. Refer to <a href="#">Note[1]</a> for details.	DSA Utility Kit
	RF adaptor kit. Refer to <a href="#">Note[2]</a> for details.	RF Adaptor Kit
	Includes: 50 $\Omega$ to 75 $\Omega$ adaptor (2pcs)	RF CATV Kit
	Includes: 6 dB attenuator (1pcs), 10 dB attenuator (2pcs)	RF Attenuator Kit
	30 dB high-power attenuator, with the max. power of 100 W	ATT03301H
	N(M)-N(M) RF Cable	CB-NM-NM-75-L-12G
	N(M)-SMA(M) RF Cable	CB-NM-SMAM-75-L-12G
	Near-field Probe	NFP-3
	USB Cable x1	CB-USBA-USBB-FF-150

**NOTE**

- For all the mainframes, accessories, and options, please contact the local office of RIGOL.
- [1]: Includes N-SMA cable, BNC-BNC cable, N-BNC adaptor, N-SMA adaptor, 75  $\Omega$ -50  $\Omega$  adaptor, 900 MHz/1.8 GHz antenna (2pcs), 2.4 GHz antenna (2pcs)
- [2]: Includes: N(F)-N(F) adaptor (1pcs), N(M)-N(M) adaptor (1pcs), N(M)-SMA(F) adaptor (2pcs), N(M)-BNC(F) adaptor (2pcs), SMA(F)-SMA(F) adaptor (1pcs), SMA(M)-SMA(M) adaptor (1pcs), BNC T type adaptor (1pcs), 50  $\Omega$  SMA load (1pcs), 50  $\Omega$  BNC impedance adaptor (1pcs)

## 7.2 Appendix B: Warranty

RIGOL TECHNOLOGIES CO., LTD. (hereinafter referred to as RIGOL) warrants that the product mainframe and product accessories will be free from defects in materials and workmanship within the warranty period. If a product proves defective within the warranty period, RIGOL guarantees free replacement or repair for the defective product.

To get repair service, please contact your nearest RIGOL sales or service office.

There is no other warranty, expressed or implied, except such as is expressly set forth herein or other applicable warranty card. There is no implied warranty of merchantability or fitness for a particular purpose. Under no circumstances shall RIGOL be liable for any consequential, indirect, ensuing, or special damages for any breach of warranty in any case.

# Boost Smart World and Technology Innovation

Industrial Intelligent  
Manufacturing



Semiconductors

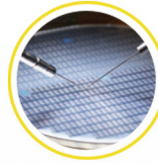

Education &  
Research

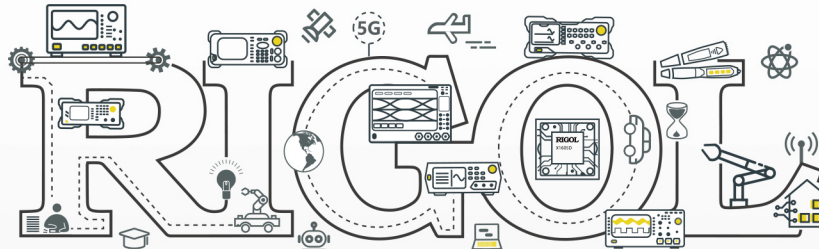

Communication

System Integration

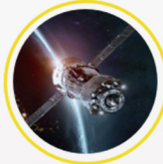

New Energy



- 5G Cellular-5G/WIFI
- UWB/RFID/ ZIGBEE
- Digital Bus/Ethernet
- Optical Communication

- Digital/Analog/RF Chip
- Memory and MCU Chip
- Third-Generation Semiconductor
- Solar Photovoltaic Cells

- New Energy Automobile
- PV/Inverter
- Power Test
- Automotive Electronics

Provide Testing and Measuring Products  
and Solutions for Industry Customers

## HEADQUARTER

**RIGOL TECHNOLOGIES CO., LTD.**  
No.8 Keling Road, New District,  
Suzhou, JiangSu, P.R.China  
Tel: +86-400620002  
Email: info-cn@rigol.com

## JAPAN

**RIGOL JAPAN CO., LTD.**  
5F, 3-45-6, Minamiotsuka, Toshima-Ku,  
Tokyo, 170-0005, Japan  
Tel: +81-3-6262-8932  
Fax: +81-3-6262-8933  
Email: info.jp@rigol.com

## EUROPE

**RIGOL TECHNOLOGIES EU GmbH**  
Friedrichshafener Str. 5  
82205 Gilching  
Germany  
Tel: +49(0)8105-27292-21  
Email: info-europe@rigol.com

## KOREA

**RIGOL KOREA CO., LTD.**  
5F, 222, Gonghang-daero,  
Gangseo-gu, Seoul, Republic of Korea  
Tel: +82-2-6953-4466  
Fax: +82-2-6953-4422  
Email: info.kr@rigol.com

## NORTH AMERICA

**RIGOL TECHNOLOGIES, USA INC.**  
10220 SW Nimbus Ave.  
Suite K-7  
Portland, OR 97223  
Tel: +1-877-4-RIGOL-1  
Email: sales@rigol.com

## For Assistance in Other Countries

Email: info.int@rigol.com